

SLAC Vertical Comparator for the Calibration of Digital Levels

Helmut Woschitz¹; Georg Gassner²; and Robert Ruland³

Abstract: Digital levels replaced spirit levels in most fields of precise height measurements because of the automation of the height readings. Three manufacturers offer digital levels with a single reading resolution of 10 μm , and for all of them systematic effects are known. In Europe several facilities for system calibration of digital levels using vertical comparators were established within the last decade. However, there still was no system calibration facility in North America. In order to guarantee the accuracy required for the alignment of experiments at the Stanford Linear Accelerator Center (SLAC) a calibration facility for the system calibration of digital levels was built. In this paper the setup of the SLAC vertical comparator is described in detail and its standard uncertainty is derived. In order to perform traditional rod calibration of conventional line-scaled rods, a CCD camera was integrated into the SLAC comparator. The CCD camera setup is also briefly described. To demonstrate the capabilities of the comparator, results of system and rod calibration are shown.

DOI: 10.1061/(ASCE)0733-9453(2007)133:3(144)

CE Database subject headings: Calibration; Digital techniques; Measuring instruments; Surveys.

Introduction

Digital levels have replaced spirit levels in most fields of precise height measurements because of the automation of height readings. Three manufacturers offer digital levels with a resolution of 10 μm and for all of them systematic effects are known (e.g., Rieger and Brunner 2000; Woschitz 2003, Chap. 6). In Europe several facilities for system calibration of digital levels, which has become the accepted method for calibrating digital levels (Heister 1994), were established within the last decade. An overview of the known existing facilities is given in Woschitz (2003, pp. 10–13) and Schwarz (2005). However no system calibration facility existed on the North American continent.

At Stanford Linear Accelerator Center (SLAC) digital levels are used for precise leveling, both for setting out and monitoring. The required accuracy can only be guaranteed by regularly checking and calibrating the leveling equipment. Therefore, the metrology department at SLAC decided to establish its own calibration facility. This setup is also used for comprehensive research and development (R&D) studies in an effort to verify the applied leveling procedures and to refine them when necessary.

In order to be able to perform traditional rod calibration for line-scaled rods a CCD camera was integrated into the SLAC

comparator. Spirit leveling with analog rods is still occasionally used in congested areas where the level's field of view becomes too obstructed for automatic height reading.

In this paper the setup of the SLAC vertical comparator is described in detail and its standard uncertainty is stated. To demonstrate the capabilities of the comparator, results of system and rod calibration are shown.

Comparator Design and Hardware

SLAC Metrology Laboratory

The laboratory is situated in an old access tunnel to the linear accelerator. Its size is about 30 m \times 5 m \times 3 m. The walls are made of concrete and have a thickness of about 1 m. As the whole laboratory, except for the portal, is about 5 m beneath the natural surface, the laboratory provides excellent thermal stability. The laboratory is air conditioned to achieve a constant temperature of 20°C, which is the accepted reference temperature for instrument calibration.

The vertical comparator was built during the year 2003. The calibration facility is designed to calibrate up to 3-m-long invar rods, both for system calibration of digital levels and for traditional rod calibration.

SLAC System Calibration Facility

The procedure of system calibration of digital levels is described in detail in Woschitz (2005). In principle, both the level and the rod are used in the calibration process and the level's output is compared to "true values." Several hundred height readings are acquired at different positions on the rod. The level is kept at a constant height and the rod is mounted vertically on a rail system where it can be moved up and down. The "true values" are acquired by reading the position of the rod with a laser interferometer (Agilent N1231A, resolution: 0.6 nm). The meteorological

¹Institute of Engineering Geodesy and Measurement Systems, Graz Univ. of Technology, Steyrergasse 30, 8010 Graz, Austria.

²SLAC, Stanford Univ., P.O. Box 20450, MS 21, Stanford, CA 94309 (corresponding author). E-mail: gassner@slac.stanford.edu

³SLAC, Stanford Univ., P.O. Box 20450, MS 21, Stanford, CA 94309.

Note. Discussion open until January 1, 2008. Separate discussions must be submitted for individual papers. To extend the closing date by one month, a written request must be filed with the ASCE Managing Editor. The manuscript for this paper was submitted for review and possible publication on November 28, 2006; approved on January 22, 2007. This paper is part of the *Journal of Surveying Engineering*, Vol. 133, No. 3, August 1, 2007. ©ASCE, ISSN 0733-9453/2007/3-144-150/\$25.00.

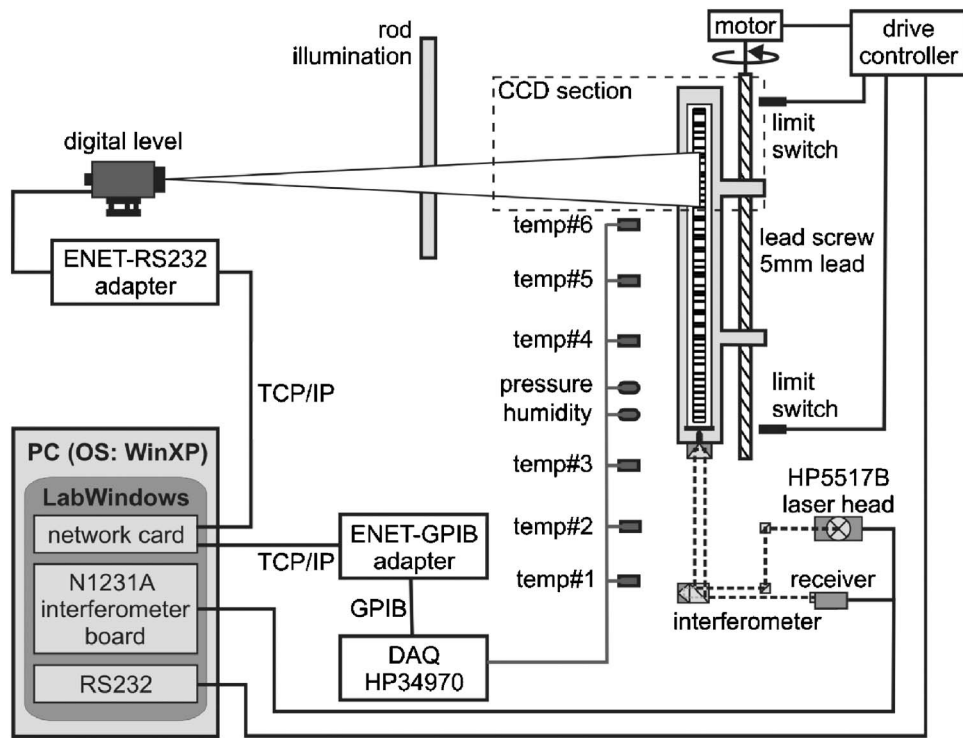

Fig. 1. Block diagram of vertical comparator for system calibration of digital levels

reduction of the interferometer distances is done using the refractive index formula of Ciddor (1996) as recommended by IAG (IUGG 1999). The representative temperature along the laser beam path is computed by modeling the vertical temperature profile that is measured by six temperature sensors (Sensor Scientific WM222C). Further sensors are an air pressure sensor (Vaisala PTB 100A) and a humidity sensor (Vaisala HMP45A). The values of all sensors are measured by an Agilent 34970A data logger and analog to digital (A/D) converter. Prior to further processing, the corresponding sensor calibration parameters are applied.

The basic setup of the comparator is schematically shown in Fig. 1. The section denoted by "CCD section" will be explained in the next section. The conceptual design of the vertical comparator system was inspired by the TUG (Graz University of Technology) design (Woschitz and Brunner 2003) and realized in cooperation with the TUG.

The whole comparator is controlled by a standard PC with Windows XP as the operating system. As the comparator system software, the TUG software (Woschitz and Brunner 2003) is used, which was converted to National Instruments "LabWindows" and adopted for the actual hardware components.

The level is mounted on a carriage that can be moved horizontally on a rail system which is attached to the ceiling (see Fig. 2). Any sighting distance between 1.65 and 30 m (this is the distance that should not be exceeded in the case of precise leveling) can be realized. The carriage was manufactured using invar and aluminum in order to keep the level at a constant height, even if there might be small temperature changes in the laboratory. It is most important that the level and the interferometer do not move with respect to each other during a calibration. The duration of a calibration mainly depends on the number of repetitive measurements by the level (e.g., about 2 h for a 3 m rod).

The interferometer is mounted at the bottom of a shaft that is 0.7 m deep and has a diameter of 0.62 m. It was necessary to drill this shaft in the floor (and another one in the ceiling) in order to

facilitate the calibration of 3 m long rods. The rod is mounted on a carriage that can be moved 3 m up and 3 m down with respect to the level's line-of-sight on a 6 m high frame. A precision lead screw (diameter: 32 mm, lead: 5 mm/rev) is used to perform the motion in combination with an index stepping motor device.

A 1.25-m-long fluorescent tube emitting a broadband spectrum is used to illuminate the rod.

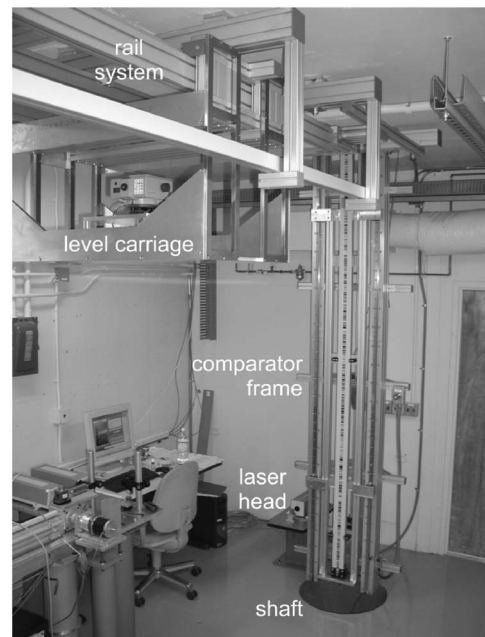

Fig. 2. SLAC vertical comparator

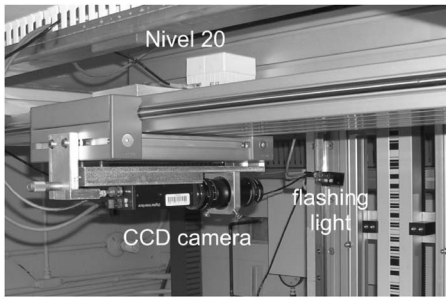

Fig. 3. CCD camera setup as part of SLAC vertical comparator

SLAC Rod Calibration Facility

Imaging System

Rod calibration has been performed since the beginning of leveling. As the level is not part of the calibration procedure, this technique is not adequate for the calibration of digital leveling systems (Heister et al. 2005). However for the continuing use of analog levels (e.g., Wild N3), line-scaled rods need to be calibrated and checked too.

To implement rod calibration on the SLAC vertical comparator, only minor modifications were necessary. A CCD camera (Sony XCD-SX900, 1,280×960 pixel, 4.65 μm × 4.65 μm/pixel) is used in combination with a telephoto lens (Schneider Kreuznach, macro iris Componon S 5.6/100, macro extension 75 mm, and macro tele 29.4 mm with $f=128$ mm and a magnification of 3.3) to detect the graduation lines on the rod. The camera is mounted to the ceiling at a distance of 420 mm from the rod. A section of 15.2 μm × 15.2 μm is projected onto each pixel, which is called pixel^{proj}. Hence, at the rod the image area is 19.4 mm × 14.6 mm in size. The illumination of the scale is realized by a flashing light that consists of 12 white LEDs. It is mounted at a distance of 160 mm from the rod. Fig. 3 shows the setup and Fig. 4 shows a schematic of its operation.

It is important that the line-of-sight of the camera is stable with respect to the interferometer during the whole calibration. Hence, a second interferometer and an inclinometer (Leica Nivel20) are used to monitor the stability of the camera (see Fig. 4). The rod readings are corrected for slight changes (micrometer range) in a postprocessing step.

During a rod calibration, the images are taken with the CCD camera while the rod is moving. The constant velocity of the rod is 1 mm/s. Therefore the camera is set to a short exposure time (1 ms). Imaging the moving rod at this velocity still causes an additional blur of 1 μm length (aside diffraction effects). Because

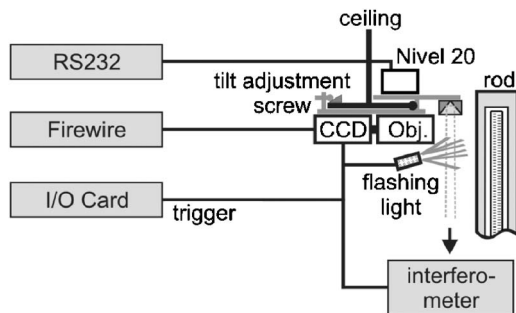

Fig. 4. Schematic overview of CCD camera part of SLAC vertical comparator (for location of CCD section see Fig. 2)

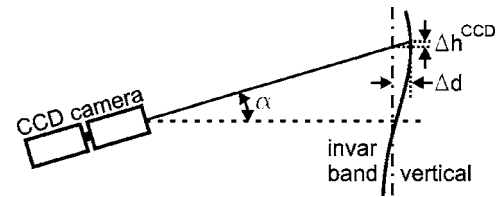

Fig. 5. Effect of tilted camera on height readings (side view)

of the short exposure time, bright illumination is needed. The illumination device is switched on for only 10 ms, during which time the LEDs emit a bright flash. The CCD camera, the LEDs, and the interferometer that monitors the rod's position are electronically triggered by a digital input–output (I/O) card (National Instruments NI6601) that generates the trigger impulse with an accuracy of 1 μs, which is sufficient (see “Standard Uncertainty of the Vertical Comparator”). The interferometer is triggered at the midtime of the CCD camera exposure.

The images taken with the CCD camera are immediately analyzed to detect edges. The commercially available “Halcon Library” (MVTec Software GmbH) for digital image processing is used for the detection of the edges of the graduation lines. The positions of the edges are stored in a file. As every edge appears in multiple images, they are analyzed in a postprocessing step together. A prerequisite for using the entire image aperture is to keep camera/lens caused distortions at a negligible level. A comprehensive investigation has shown no significant values for camera/lens distortions (<1 μm).

Leveling of CCD Camera

The line-of-sight of the CCD camera must be horizontal in order to avoid errors caused by a changing distance between the camera and the scale of the rod. Distance variations (Δd) might be in the range of several tenths of mm and are caused by a slightly twisted or bent rod, which is an artifact of the rod's manufacturing process and by play of the invar tape within its guidance grooves. Reading errors Δh^{CCD} are of the size of $\Delta h^{CCD} = \Delta d \tan \alpha$, where α is the misalignment of the line-of-sight, see (Fig. 5). For estimating the required precision for the horizontal alignment of the camera, the maximum offset Δd (see Fig. 5) is assumed not to exceed 1 mm and Δh^{CCD} is assumed to be smaller than the best precision of edge detection (pixel^{proj}/100). Based on these parameters the camera needs to be horizontally aligned within $|\alpha| < 0.009^\circ$. A prerequisite to horizontally align the camera is that the yaw of the camera is adjusted to be close to zero. The camera housing is used to position the camera perpendicular to the rod within 1 mm at a 420 mm distance. This is sufficient to reduce the perspective effect of the image to the micrometer level, which is sufficient to achieve the precision of the tilt value. Later, for the rod calibration it is necessary to take the small misalignments of the yaw and the roll into account.

The leveling of the camera is achieved prior to a calibration measurement. The center of the camera's CCD array and the camera's optical axis are not precisely known with respect to the camera housing. Therefore an alternative method was used to level the CCD camera. The procedure involves imaging the spots of two horizontal laser beams that are projected onto a flat, vertical, surface that is mounted first 5 mm in front and subsequently 5 mm behind the plane of the rod scale, (see Fig. 6). This uses the camera's whole depth of focus (i.e., 10 mm).

From the positions of the two laser points in the two images the tilt α and the roll ω of the camera can be computed, as well as

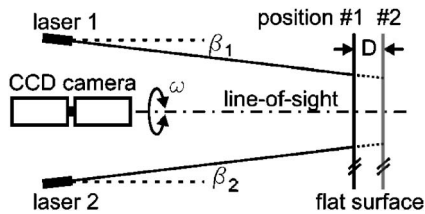

Fig. 6. Top view of setup used for horizontal alignment of CCD camera

the orientation of the two lasers with respect to the flat surface (β_1 and β_2). Then, the camera is adjusted using the tilt adjustment screw and the whole procedure is repeated to check for correct alignment. Measuring the housing of the CCD camera and a target visible with the CCD camera using an optical level showed that the results coincided well for the actual setup.

One prerequisite for the procedure described above is that the two laser beams are aligned horizontally. The distance between the laser tube and the projection surfaces is about 1 m. When measuring the vertical position of the laser beam (spot at a flat surface) close to the laser tube and close to the rod, a measurement precision of 0.1 mm is sufficient to be able to align the laser beam horizontally with the precision of 0.009° mentioned above. This precision can be achieved with an optical level.

Calibration Procedure

System Calibration

For the scale determination a refinement of the procedure proposed by Rüeger and Brunner (2000) is used, which is described in detail by Woschitz (2005). In principle, each calibration run is done twice, where the rod is remounted before the second calibration. This allows the detection of mechanical problems of the rod, e.g., a malfunction of the tension device. The measurement positions at the rod must meet special conditions (Woschitz 2003, Chap. 7) in order to get the scale factor with a precision of better than 0.3 ppm and to avoid aliasing effects. The latter might be introduced by the physical imperfections of the image sensors used in the levels, leading to cyclic deviations (see Woschitz 2003, Chap. 6). Disregarding the aliasing effects might give scale errors of several ppm (see Woschitz 2003, pp. 179–188). As the physical properties of different levels may vary slightly, even for levels of the same type, different sampling intervals are used for the calibration runs (Woschitz 2005). For example, when using a Leica level in combination with a 3 m rod, the sampling intervals are 20.573 and 20.643 mm.

Each calibration run consists of a forward measurement from the footplate of the rod to its top and a backward measurement in the opposite direction in order to detect drifts like that of the level's line-of-sight. Performing three separate height readings with the level at each rod position, one calibration run takes about 2 h.

Rod Calibration

The principal operation, i.e., the acquisition of the images and edge detection, of the rod comparator facility is described in "SLAC Rod Calibration Facility."

For the determination of the scale factor all graduation lines

are taken into account. False edges, e.g., edges caused by dirt on the invar band, can be eliminated as the positions of the graduation lines are known for each type of digital level. It must be mentioned here that the rod should be kept clean at all times as dirt on the rod may also be imaged by the level, which may cause reading errors of several millimeters, like damaged code elements (see Woschitz 2003).

Also with rod calibration, each calibration run consists of a forward and a backward measurement in order to detect drifts. With a velocity of 1 mm/s the time for one calibration run (forward and backward measurement) is approximately 1.5 h for a 3 m rod.

The result of a calibration run is a file containing the positions of the edges, the rod positions, atmospheric measurements, and information about the stability of the CCD camera (interferometer and Nivel20 readings). Due to the continuous movement of the rod, every edge is visible in several images. Its edge positions and the corresponding laser interferometer positions are analyzed together in order to compute the vertical position of the edge at the rod by means of a least squares adjustment. There, the scale factor of the image, its rotation, and the roll of the CCD camera are estimated as additional parameters. The whole computation is done in preprocessing using Matlab routines.

Standard Uncertainty of Vertical Comparator

In a calibration process the measurement values of an instrument are compared to true values. It is the basic task of a comparator to provide these true values. In the case of the vertical comparator, the fundamental unit of the true values is the "meter" and this unit is primarily defined by the frequency of the interferometer's laser tube, which was calibrated for traceability to national standards.

Second, the wavelength of the laser beam is also a function of the refractive index of ambient air, which is why the measured interferometer distances must be reduced in order to obtain the "true values." The most common approach for obtaining a value of the refractive index is to model it using temperature and air pressure measurements. However, this modeling process is affected by the precision of the measurement of the meteorological parameters and the model used. Aside from the uncertainties of the interferometer measurement, there are many other parameters that can bias the calibration, like misalignments or instabilities of components.

Some parameters may be eliminated by an adequate calibration procedure (see e.g., Woschitz 2005), others remain in the process. As it is too complex to measure all quantities of influence at every calibration, the true values can never be derived exactly. However it is of importance to know about the deviations from the true values in order to be able to state the uncertainty of the calibration measurement.

The ISO/BIPM (1995) *Guide to the expression of uncertainty in measurement* (GUM) allows the estimation of the uncertainty of complex measurement systems. Quantities that cannot be measured may also be taken into account (e.g., Heister 2001). The first step is to establish a model of the whole measuring process. The distance measurement L by the interferometer may be expressed as

$$L = (C + \Delta C^{EE} + \Delta C^{NL} + \Delta C^{TD}) \cdot \frac{\lambda}{R \cdot n} \cdot \cos \alpha + \frac{D}{\Delta n} + \Delta L^{TG} \quad (1)$$

Table 1. Description of Terms and Standard Uncertainties

Symbol	Description	Standard uncertainty	
		System calibration	Rod calibration
C	number of counts measured by the interferometer (1 count= $\lambda/1,024$)		34.6 counts
ΔC^{EE}	interferometer electronic error		0.6 counts
ΔC^{NL}	interferometer optics nonlinearity		4.5 counts
ΔC^{TD}	interferometer optics thermal drift		46.7 counts
λ	wavelength of the laser head ($\lambda \approx 633$ nm)		0.01 ppm
R	resolution of the interferometer		—
n	refractive index of air		0.26 ppm
α	misalignment of comparator frame and laser beam		0.012°
D	dead path distance	5.8 mm	1.2 mm
Δn	change of the refractive index during the calibration run		1.3 ppm
ΔL^{TG}	effect of the trigger (at rod velocity of 10 mm/s)	0 μm	1.7 nm
A	comparator constant; vertical spacing between the interferometer and the level		0.6 μm
ΔL^{LC}	vertical shift of the level caused by thermal expansion of the carriage due to temperature changes in the laboratory / position correction of the CCD camera by interferometric measurement	0.02 μm	0.4 μm
ΔL^{CS}	vertical shift of the ceiling due to diurnal temperature changes outside the laboratory	0.1 μm	0.1 μm
ΔL^{LOS}	change of the level's or CCD camera's line-of-sight during a calibration run (eliminated by measuring procedure) / remaining tilt of the CCD camera's line-of-sight and corrections by the inclinometer readings	0 μm	0.3 μm
ΔH^R	remaining height offset of the level / CCD camera measurement caused by its resolution, despite repetitive measurements	1 μm	0.4 μm
γ	misalignment of the rod due to winding of rod's housing		0.004°
ΔL^S	thermal expansion of the rod's invar band		0.6 μm

Each term in Eq. (1) is explained in Table 1. Furthermore, a vertical comparator measurement H , which is the interferometer measurement with respect to the digital level or the CCD camera, respectively, is also influenced by external parameters

$$H = (A - L + \Delta L^{LC} + \Delta L^{CS} + \Delta L^{LOS} + \Delta H^R) \cdot \frac{1}{\cos \gamma \cdot (1 + \Delta L^S)} \quad (2)$$

Again the terms of Eq. (2) are listed in Table 1. Additionally, the estimates of the standard uncertainties of the terms are given in Table 1, both for system and rod calibration. Differences between the two are caused by the different setups. The standard uncertainties were determined using the results of dedicated experiments. Where experimental values were not available, the values were assigned using experience or were obtained from the literature. Some of the standard uncertainties listed in Table 1 had to be estimated using the GUM procedure, e.g., the combined standard uncertainty of the refractive index n , which was determined using the uncertainties of the meteorological sensors, of the measurement, and the formula used. The “law of propagation of uncertainty” (ISO/BIPM 1995) was applied to Eqs. (1) and (2) to

determine the combined standard uncertainty $u_c(H)$ for an interferometer distance of 3 m. In this paper the partial derivatives of Eqs. (1) and (2) are not explicitly stated.

To determine the expanded standard uncertainty $U(H)$ of a comparator measurement H , a coverage factor of $k=2$ was used, giving $U(H)_{SC} = \pm 2.8 \mu\text{m}$ for system calibration and $U(H)_{RC} = \pm 2.4 \mu\text{m}$ for rod calibration. With this factor k , the level of confidence is approximately 95%.

The derived standard uncertainty $U(H)_{SC} = \pm 2.8 \mu\text{m}$ ($k=2$) for system calibration is quite similar to the one of the TU Graz comparator, which is $U(H)_{SC} = 2.7 \mu\text{m}$ with $k=2$ (Woschitz and Brunner 2003). The reason is that the limiting factors (resolution of the level's height reading, acquisition of the appropriate refractive index) are similar for both comparators.

Using all comparator measurements, the scale factor β can be derived using linear regression analysis. Its expanded standard uncertainty can be derived using the “law of propagation of uncertainty” again, which results in $U(\beta)_{SC} = \pm 1.4$ ppm ($k=2$) for the system calibration of Leica instruments using 3 m rods, and in $U(\beta)_{SC} = \pm 2.3$ ppm ($k=2$) for Trimble instruments using 2 m rods for example.

The uncertainties are little smaller for rod calibration: $U(\beta)_{RC} = \pm 1.2$ ppm ($k=2$) for 3 m rods, and in $U(\beta)_{RC} = \pm 1.8$ ppm ($k=2$) for 2 m rods.

Table 2. Calibration Results from System Calibration and Rod Calibration

Rod (S. number)	Rod length (m)	System calibration		Rod calibration	
		scale factor (two runs) (ppm)	$U(\beta)_{SC}$ ($k=2$) (ppm)	scale factor (ppm)	$U(\beta)_{RC}$ ($k=2$) (ppm)
Leica (9946)	3	0.1/0.5	± 1.4	-0.1	± 1.2
Leica (9960)	3	-0.8/-0.5	± 1.4	-1.3	± 1.2
Trimble (13710)	2	-0.0/-0.3	± 2.3	-1.3	± 1.8
Trimble (13702)	2	2.9/2.4	± 2.3	0.1	± 1.8

Examples of System and Rod Calibration

In this section, results of system and rod calibration are shown in order to give an impression about the capabilities of the comparator.

For system calibration, two different digital levels (Leica DNA03, Trimble DiNi12) were used, each with two rods. For the Leica instrument rods of 3 m length were available and for the Trimble instrument 2 m long rods. The rod calibration was carried out using the same rods. It must be explicitly stated that rod calibration is not intended to be used for rods of digital levels as the level is excluded from the calibration process. It is done in this case in order to show that the scale factors determined by rod calibration and system calibration are almost identical, if the height readings acquired with the level do not show any systematic behavior.

The results of the system and rod calibrations are given in Table 2. Additionally, the standard uncertainties U with an expansion factor of $k=2$ (see “Standard Uncertainty of the Vertical Comparator”) are listed for the scale factors.

For the Leica rods the scale factors determined by system and rod calibration differ at maximum by 0.8 ppm, see Table 2. Considering the levels of uncertainty, they are not different.

Fig. 7(a) shows the deviations ΔL of the graduation lines of a Leica rod from their designed positions that were determined by rod calibration. Additionally, the determined scale factor is drawn

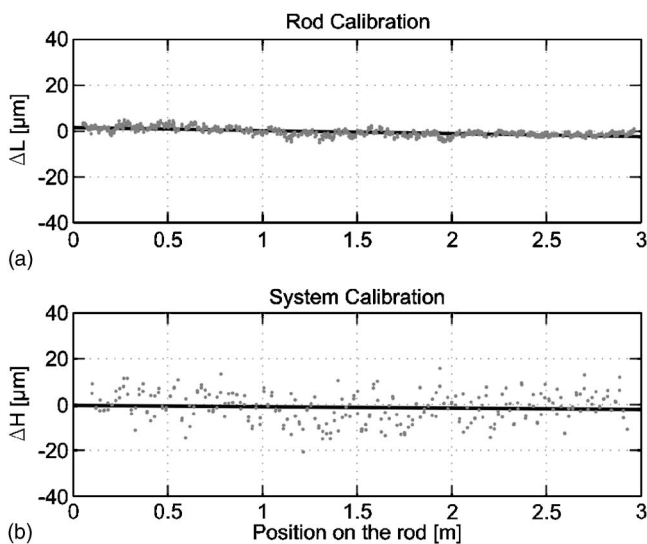

Fig. 7. Calibration results for Leica rod 9960 determined: (a) by rod calibration; (b) by system calibration in combination with Leica DNA03

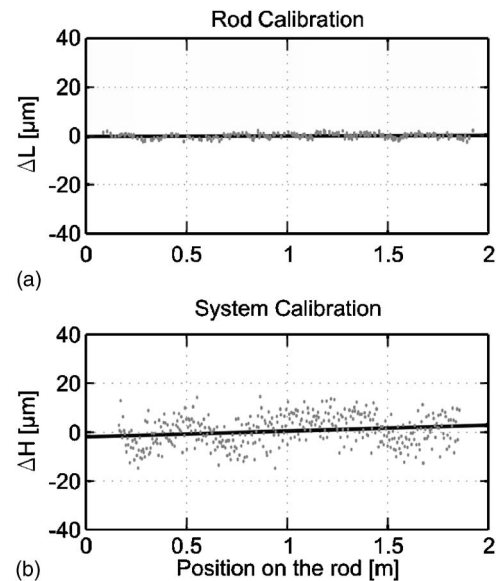

Fig. 8. Calibration results for Trimble rod 13702 determined: (a) by rod calibration; (b) by system calibration in combination with Trimble DiNi12

as a straight line. The precision of the detected edges is $0.7 \mu\text{m}$ and the maximum deviation of the regression line is about $6 \mu\text{m}$. This corresponds well to the specifications published by the manufacturer (random errors of the code elements positions are smaller than $7 \mu\text{m}$ (see Fischer and Fischer 1999).

Fig. 7(b) shows the deviations ΔH of the level’s height readings (Leica DNA03, S. Number 333858) with respect to “true values,” determined by system calibration. Three individual height readings were taken by the digital level at each rod position and the mean value was calculated for the graph. The precision of the height reading at a specific staff position is $8 \mu\text{m}$ and mainly influenced by the sampling interval used and the resolution of the level. The variation of the residuals is quite random.

Fig. 8 shows the corresponding calibration results for a 2 m rod and a Trimble DiNi12 (S. Number: 701116). As before, the deviations of the graduation lines determined by rod calibration are smaller than $6 \mu\text{m}$ [see Fig. 8(a)].

For the system calibration the mean values of three individual height readings with the level are used to compute the deviations of the regression line. These are plotted in Fig. 8(b). Again, the precision of the height readings at a specific staff position is $8 \mu\text{m}$. The residuals show a systematic behavior corresponding to the position on the rod.

The systematic pattern that can be seen in Fig. 8(b) is only present when using Trimble instruments. The reason for this pattern is not known yet, but it is most obvious that it is an artifact of the measurement process of the level and its software. With the vertical comparator, a powerful instrument is available to do detailed investigations in the future. However, one must keep in mind that this effect is very small and of the size of the resolution of the level ($10 \mu\text{m}$).

However, the scale factor determined by system calibration includes this systematic pattern and the differences between the scale factors determined by rod and system calibration are larger (at maximum 2.8 ppm, see Table 2). However, even in this case the differences of the scale factors are marginally below the level of significance.

In general, the scale factor determined by system calibration

and not the one determined by rod calibration must be applied to all the measurements with digital levels, as the level is included in the calibration process.

Conclusion

The calibration facility presented has proven itself to be a valuable addition to the SLAC metrology laboratory. It is the prerequisite for the detailed investigation of digital leveling systems in order to improve the field procedures that are currently used by the SLAC metrology group and as a consequence to improve the precision of the field measurements (Gassner et al. 2004; Woschitz 2003). Furthermore, it is an indispensable tool for testing the leveling equipment thoroughly before every major measurement campaign and therefore being able to guarantee the needed accuracy.

The expanded standard uncertainty of both calibration methods, the system calibration ($U(H)_{SC} = \pm 2.8 \mu\text{m}$, $k=2$) and the rod calibration ($U(H)_{RC} = \pm 2.4 \mu\text{m}$, $k=2$), are sufficient to calibrate digital leveling systems that have a resolution of $10 \mu\text{m}$. For traceability, an experiment using system and rod calibrations at SLAC and different European calibration sites is planned for the near future.

Acknowledgments

The writers would like to thank B. Dix and Z. Wolf, both at the SLAC Metrology Department, for helping to build the comparator. Furthermore, they appreciate the assistance of Professor F. K. Brunner, Graz University of Technology. The work was supported by the U.S. Department of Energy under Contract No. DE-AC03-76SF00515. The SLAC publication number is SLAC-PUB-12207.

References

- Ciddor, P. E. (1996). "Refractive index of air: New equations for the visible and near infrared." *Appl. Opt.*, 35, 1566–1573.
- Fischer, T., and Fischer, W., (1999). "Manufacturing of high precision levelling rods." *The importance of heights*, M. Lilje, ed., FIG, Gävle, Sweden, 223–228.
- Gassner, G., Ruland, R., and Dix, B. (2004). "Investigations of digital levels at the SLAC vertical comparator." *Proc., IWAA2004 Conf.*, Geneva, Switzerland.
- Heister, H. (1994). "Zur Überprüfung von Präzisions-Nivellierlatten mit digitalem Code." *Schriftenreihe Nr. 46* Univ. der Bundeswehr München, München, Germany, 95–101.
- Heister, H. (2001). "Zur Angabe der Messunsicherheit in der geodätischen Messtechnik." *Qualitätsmanagement in der geodätischen Messtechnik*, H. Heister and R. Staiger eds., DVW Schriftenreihe 42, Konrad Wittwer Verlag, Stuttgart, Germany, 108–119.
- Heister, H., Woschitz, H., and Brunner, F. K. (2005). "Präzisionsnivellierlatten, Komponenten-oder Systemkalibrierung?" *Allgemeine Vermessungs-Nachrichten*, 112, 233–238.
- International Organisation of Standards (ISO/BIPM). (1995). *Guide to the expression of uncertainty in measurement*, Geneva, Switzerland.
- International Union of Geodesy and Geophysics (IUGG) (1999). "XXII General Assembly IUGG." *Proc.*, Univ. of Birmingham, Birmingham, U.K., (<http://iugg.org/assemblies/1999birmingham/1999crendus.pdf>).
- Rüeger, J. M., and Brunner, F. K. (2000). "On system calibration and type testing of digital levels." *Zeitschrift für Vermessungswesen*, 125, 120–130.
- Schwarz, W. (2005). "Komparatoren zur Überprüfung von präzisionsnivellierlatten." *Allgemeine Vermessungs-Nachrichten*, 112, 204–212.
- Woschitz, H. (2003). *System calibration of digital levels: Calibration facility, procedures and results*, Shaker Verlag, Aachen, Germany.
- Woschitz, H. (2005). "Systemkalibrierung: Effekte von digitalen Nivelliersystemen." *Allgemeine Vermessungs-Nachrichten*, 112, 239–244.
- Woschitz, H., and Brunner, F. K. (2003). "Development of a vertical comparator for system calibration of digital levels." *Österreichische Zeitschrift für Vermessung und Geoinformation*, 91, 68–76.