

Gastvorträge

Reluctance electric machines: an overview and perspective

Prof. Ion BOLDEA, University Politehnica Timisoara (UPT), Romania

Donnerstag, 20. September 2018, 14:00 Uhr

Bibliothek des Institutes EAM, Inffeldgasse 18/1 (HS01020F)

Electric energy savings and increased industrial productivity require ever better electric machines with intelligent digital control. Besides induction machines, which come at the drawback of large rotor losses, permanent magnet (PM) machines with the drawback of expensive PMs with risk of demagnetization at heavy loads and dc excited synchronous machines with notable rotor losses, reluctance synchronous and flux modulation electric machines and drives have been thoroughly investigated lately. The

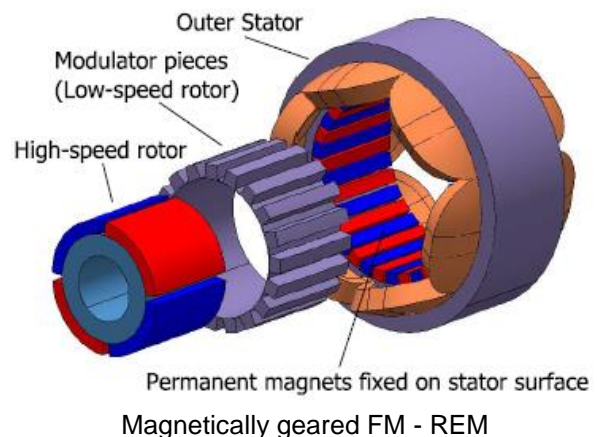

presentation includes the high-saliency reluctance synchronous machines for line start and premium efficiency and for variable speed drives, together with a myriad of reluctance effect electric machines under the name of flux-modulation machines: claw-pole machines, transverse flux machines, flux switch machines, flux reversal machines, BLDC multiphase reluctance machines (MRM), brushless doubly fed reluctance machines (BDFRM), Vernier PM machines, magnetically geared electric machines, all with their advantages and drawbacks and potential applications..

Prof. Ion BOLDEA, IEEE Fellow (1996), Life Fellow (2011) has worked and published extensively, mostly within IEEE, on linear and rotary electric machines' modeling, design, testing and control, and on MAGLEVs over the last some 40 years; he has held IEEE-IAS Distinguished Lectures since 2008, intensive courses, key note addresses in the USA, S. America, Europe and S. Korea, as well as at IEEE sponsored conferences and published numerous books on the subject of his expertise in USA and UK. He is also the recipient of the IEEE 2015 Nikola Tesla Award.

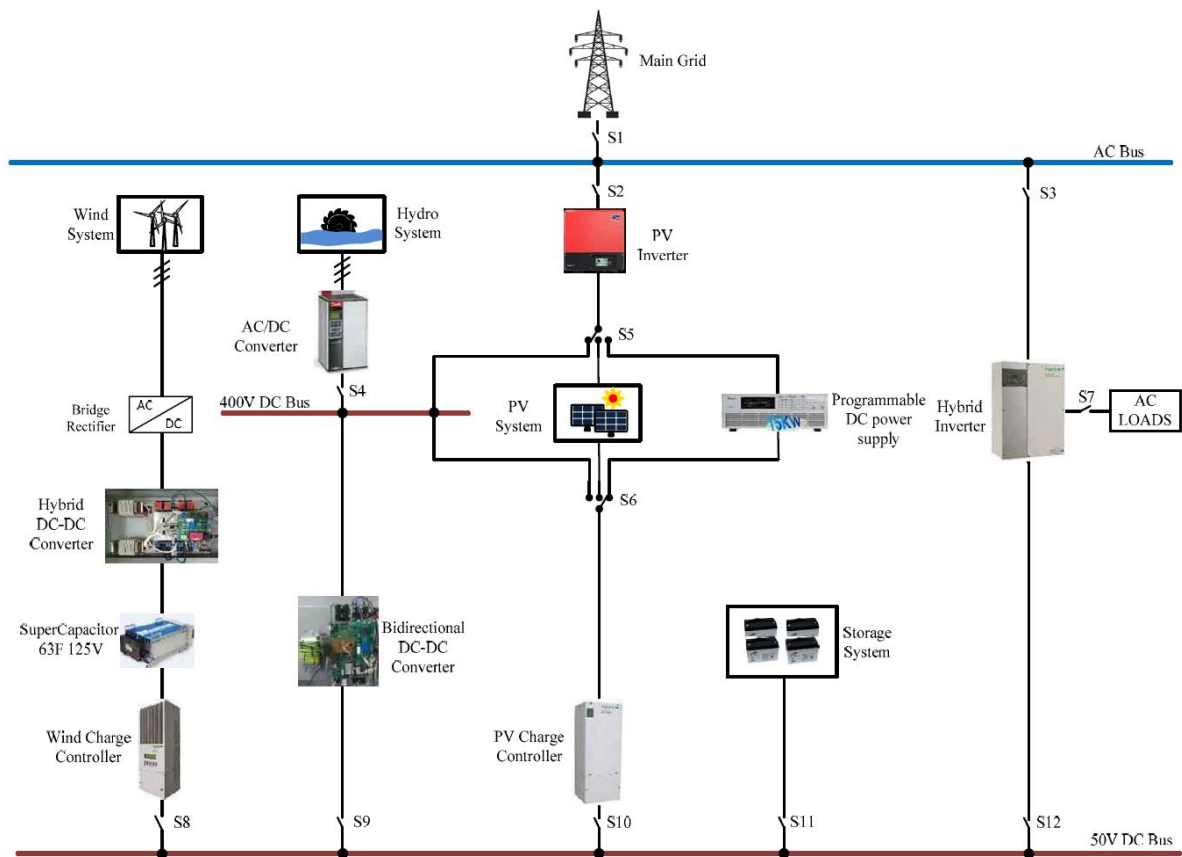

UPT microgrid topology

UPT Smart Small Multi-Source DC and AC Bus Power Grid

Prof. Nicolae MUNTEAN, University Politehnica Timisoara (UPT), Romania

Donnerstag, 20. September 2018, 15:00 Uhr
Bibliothek des Institutes EAM, Inffeldgasse 18/1 (HS01020F)

The microgrid concept has been widely adopted due to its ability to integrate renewable and conventional energy sources with load and storage elements, in an intelligent energy management system. The UPT microgrid laboratory setup (Figure above) has been designed and implemented to investigate different configurations and control strategies. The system is fully configurable, both in terms of hardware and software implementation, and allows different microgrid structures which may include one, two or all sources, and configurable storage and load elements.

Possible power sources are: PV, wind, and hydro systems. HIL emulators are used to implement the wind and hydro turbine characteristics in the test laboratory. The electrical energy is distributed through DC and AC buses. The laboratory microgrid can work both in on-grid and off-grid regimes. The entire system is coordinated through a SCADA application.

Prof. Nicolae MUNTEAN, *IEEE Senior Member*, has worked and published on power electronic converters and systems - design, testing and control, in various applications, such as variable speed drives, renewable energy conversion systems, and automotive DC-DC converters. He has experience in industry applications, especially in VSD implementation (up to 1.2 MW power/unit, with multilevel and cellular converters, at 6kV), and in energy efficiency audits and consulting activities. He is the director of the research center "Control of energy conversion and storage", at UPT.