

Co-Elektrolyse als Schlüsseltechnologie in Power-to-X Anwendungen

Daniel Reiner

Srđan Marković, Hartmuth Schröttner, Christoph Hochenauer, Vanja Subotić

Technische Universität Graz
Institut für Wärmetechnik (IWT)
Inffeldgasse 25/B
8010 Graz

EnInnov2026

19. Symposium Energieinnovation | 11.02.-13.02.2026

Motiviation

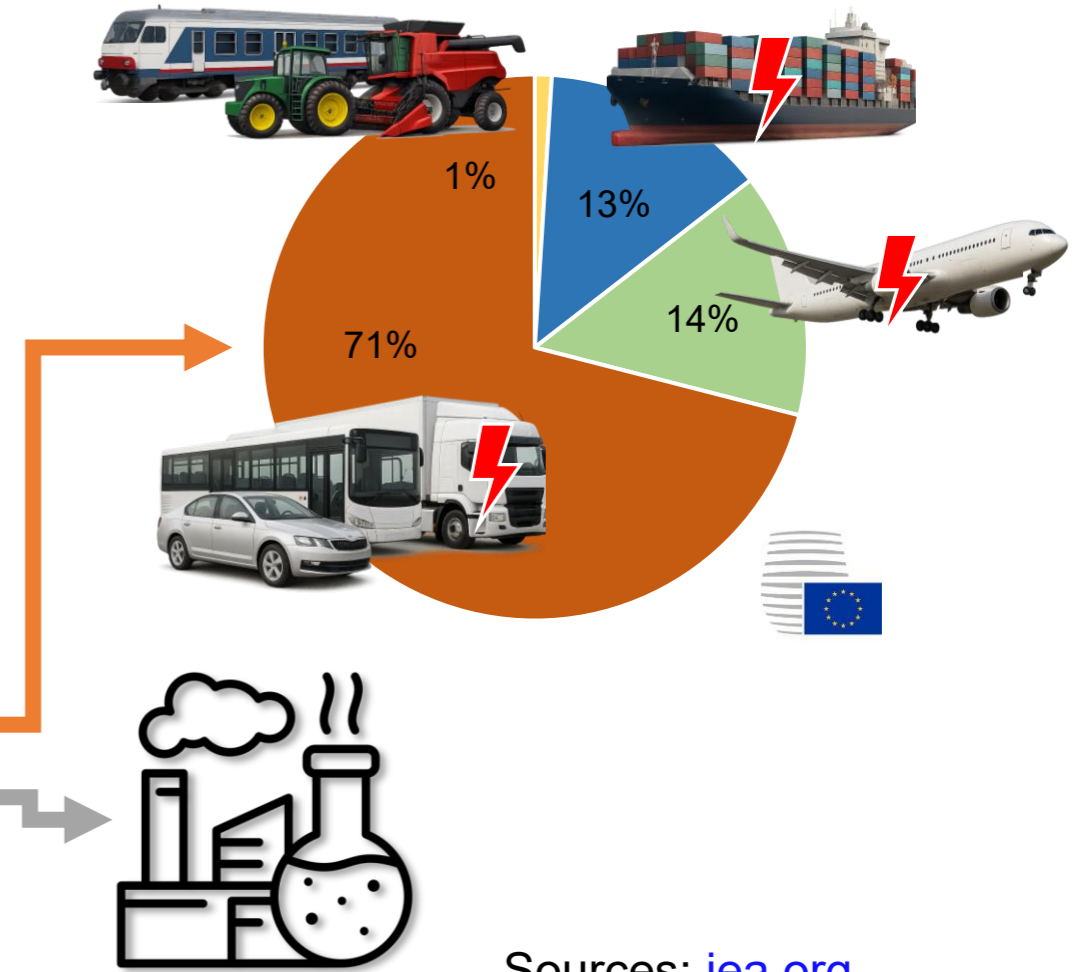
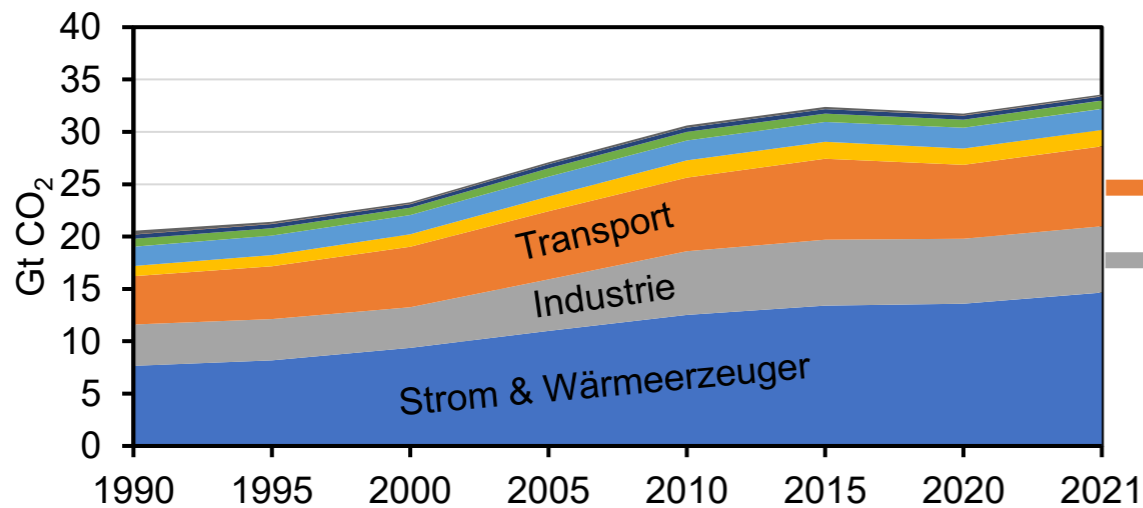
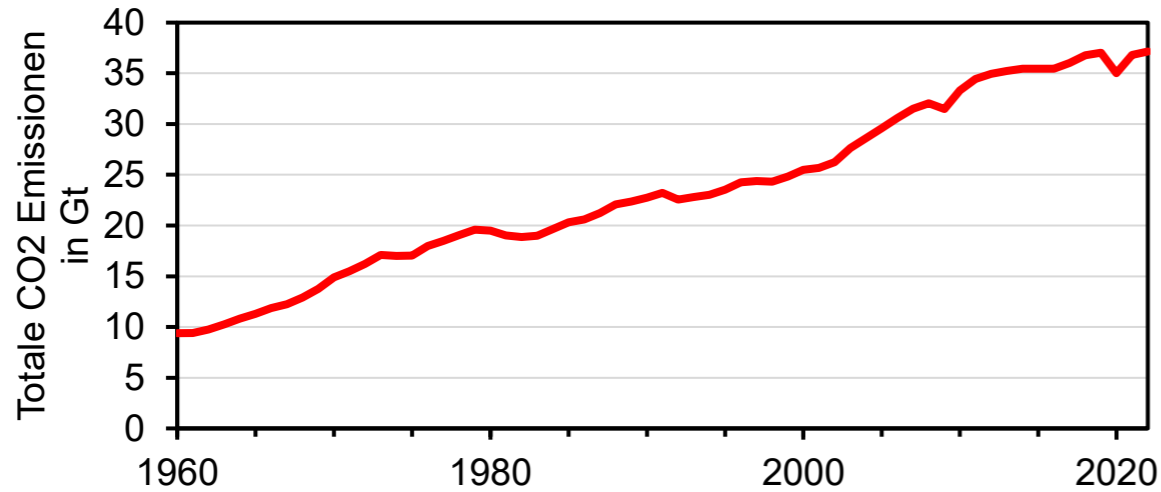

Sources: iea.org
consilium.europa.eu

Warum Power-to-X?

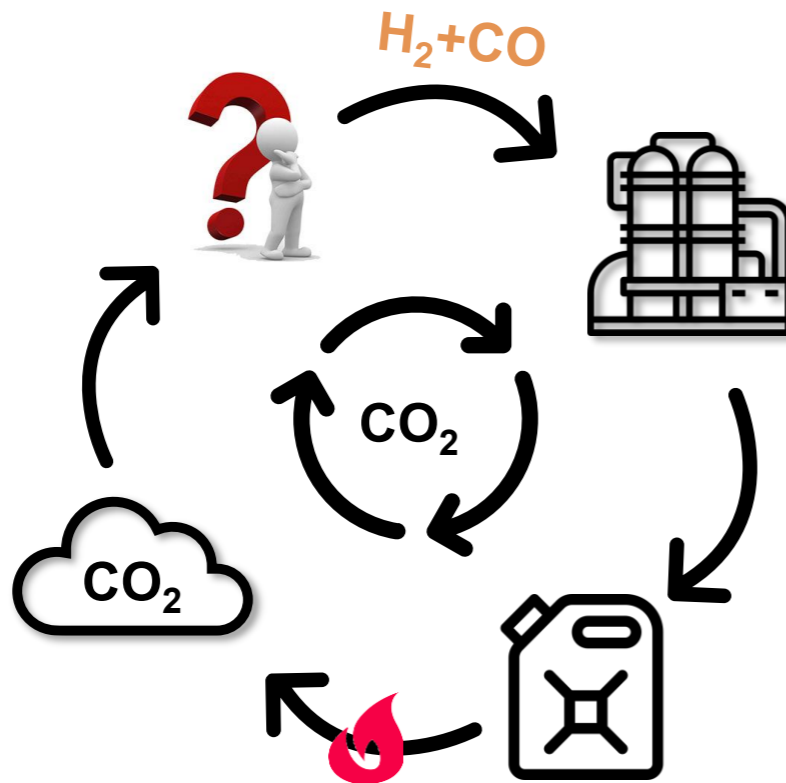

 Power-to-X

 Klimaneutral

 Bestehende Infrastruktur

 Nachhaltige Synthesegas

Power-to-X (PtX)

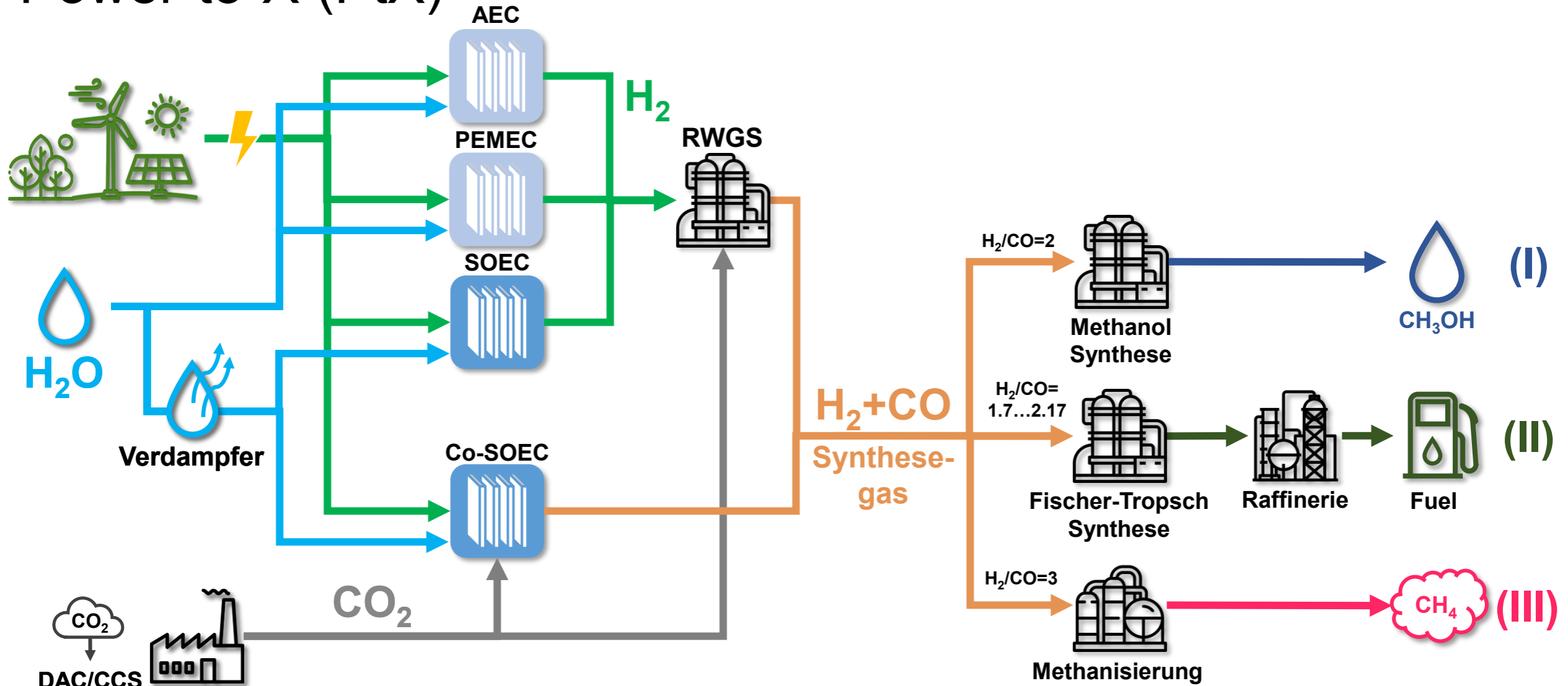

Funktionsprinzip der Co-Elektrolyse

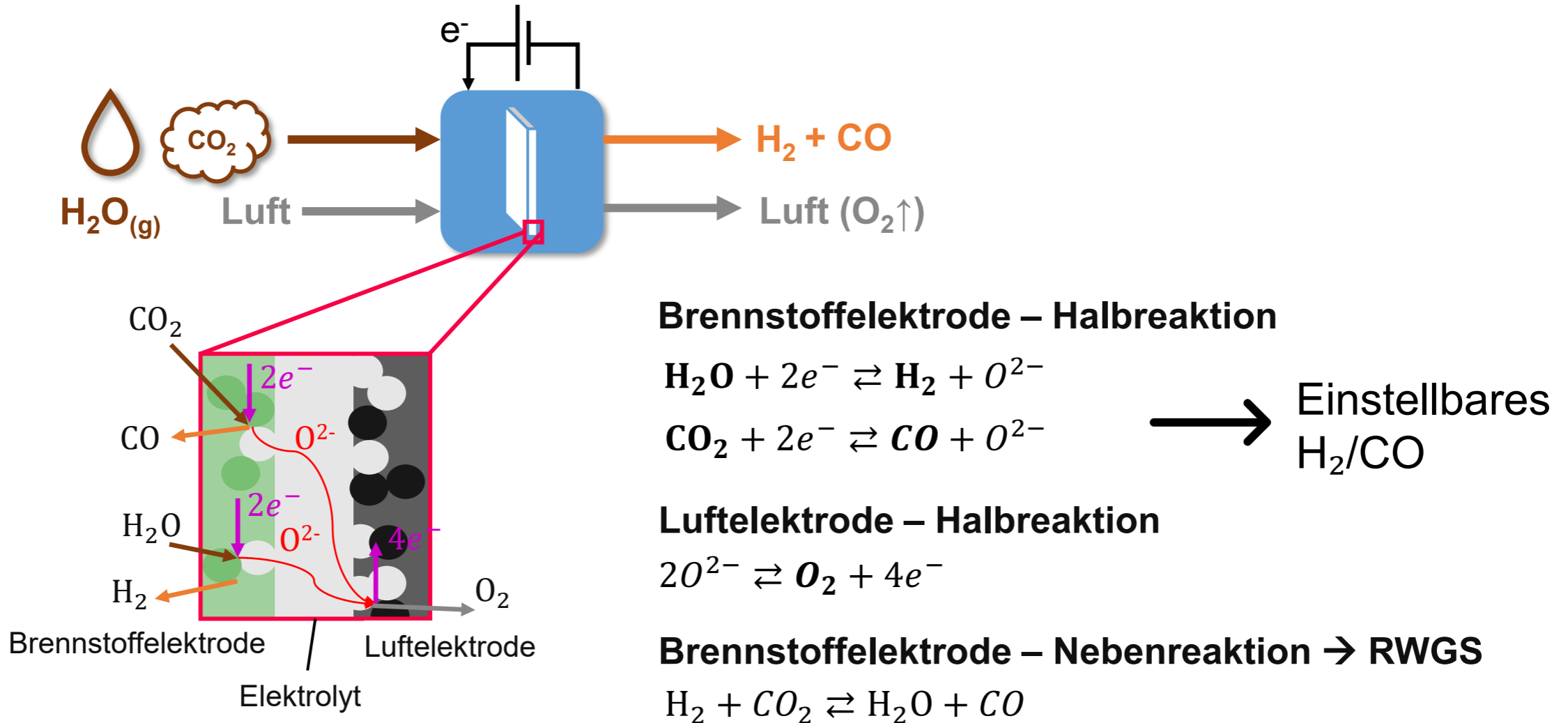

Unser Konzept

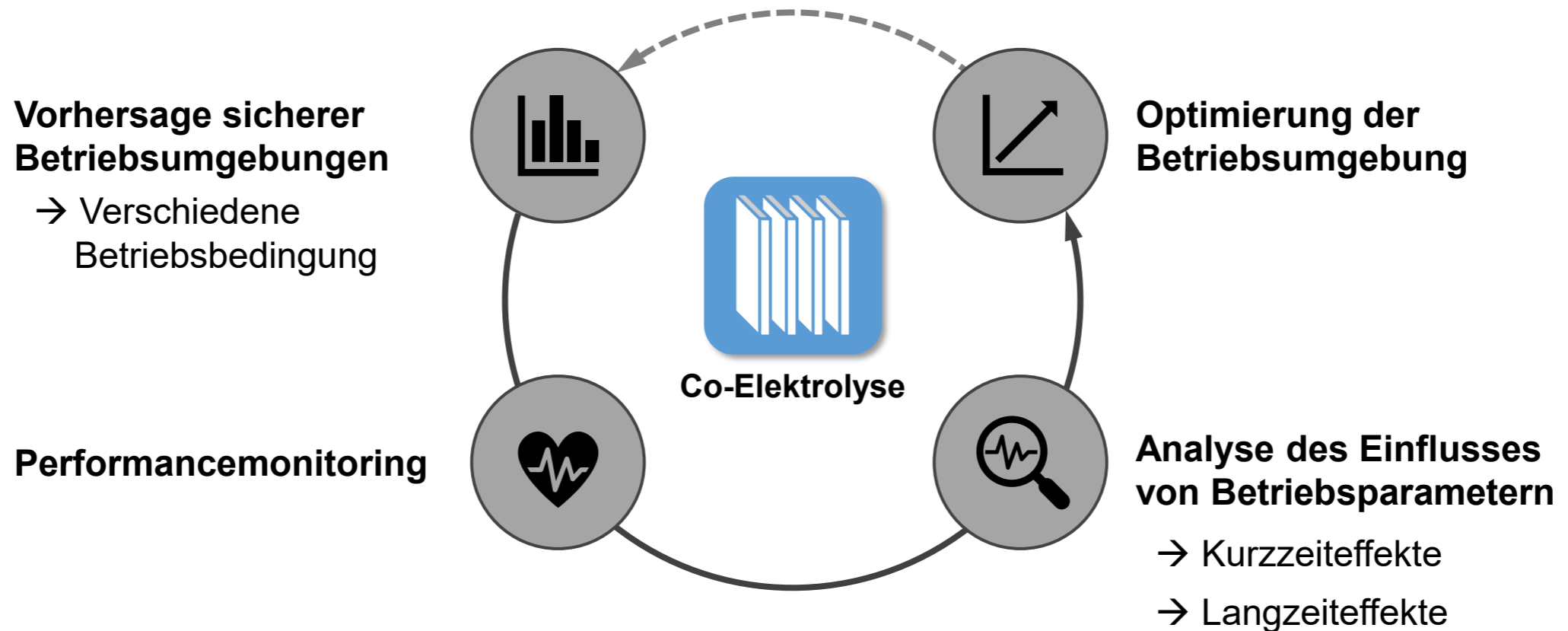

Versuchsaufbau

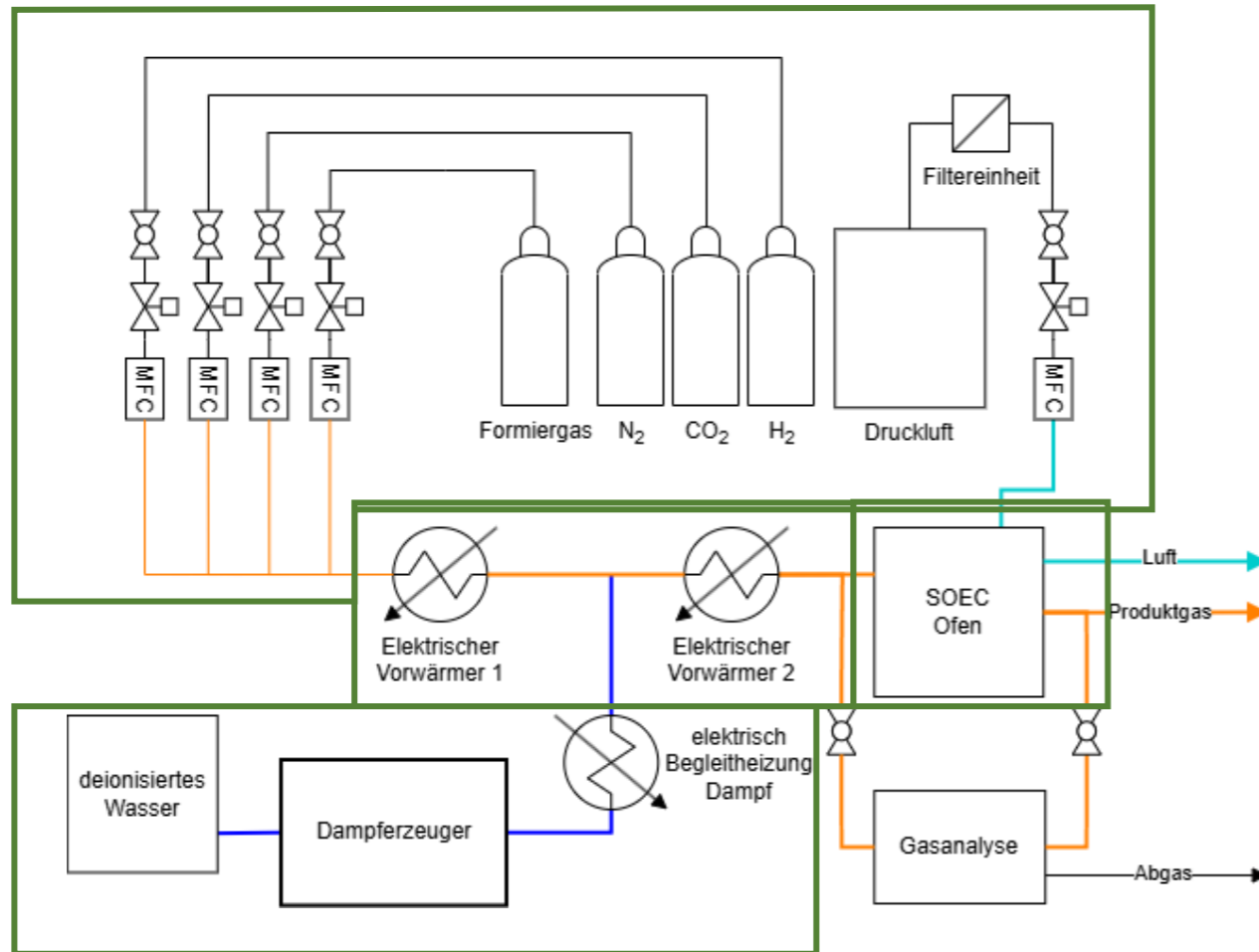

Versuchsaufbau

- Keramisches Zellgehäuse
- Ermöglicht Temperaturmonitoring
- Brennstoffelektroden gestützte SOEC (active area = 81 cm²)

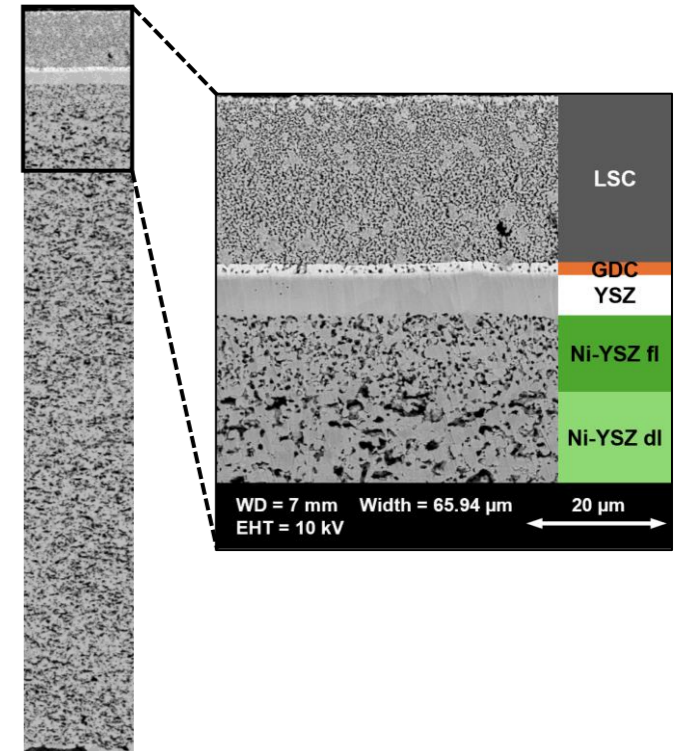
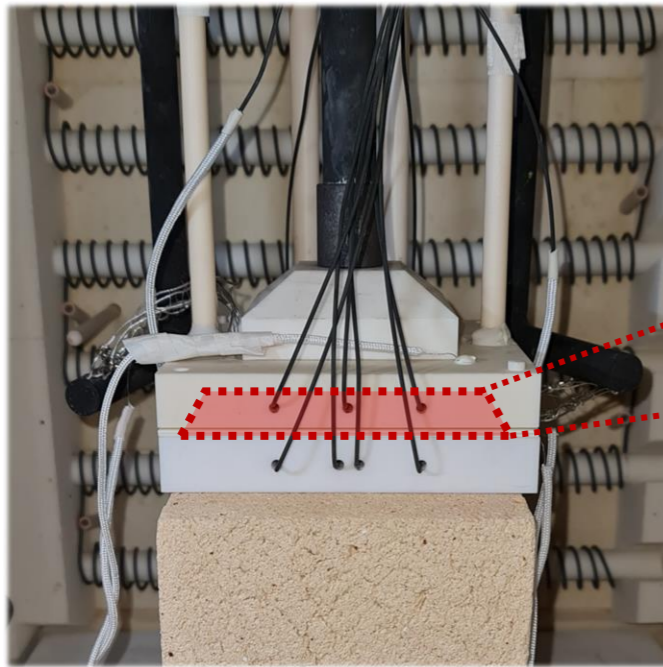

Messmethoden

- Spannungs-/Stromrelation
 - Galvanostatischer Betrieb:
 - Stromgesteuert
 - Spannung gemessen
- Elektrochemische Impedanzspektroskopie – EIS
 - AC-Anregung bei Gleichstrom
 - Spannungsantwort messen
 - Frequenzvariation

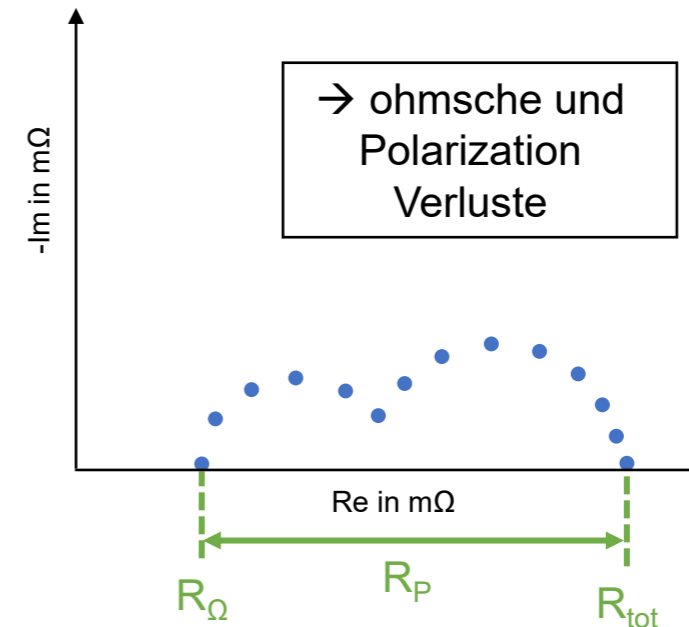
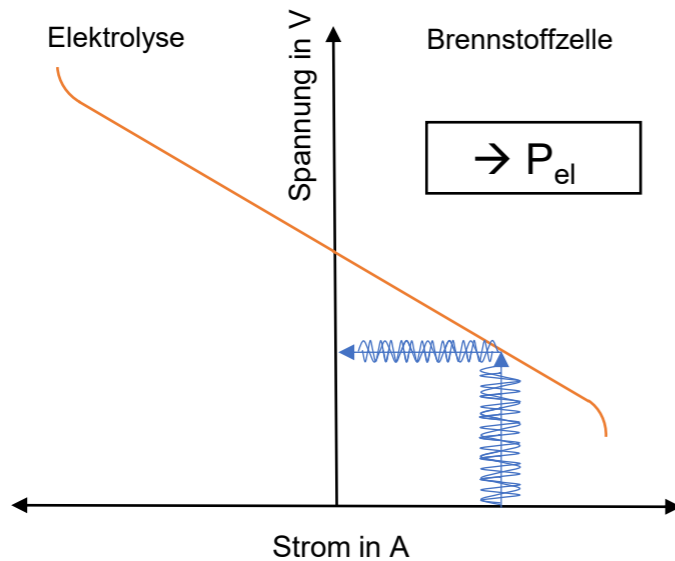

Co-Elektrolyseversuche

- Betriebstemperatur 800°C
- Stromdichte 750mA/cm² (60.75A)

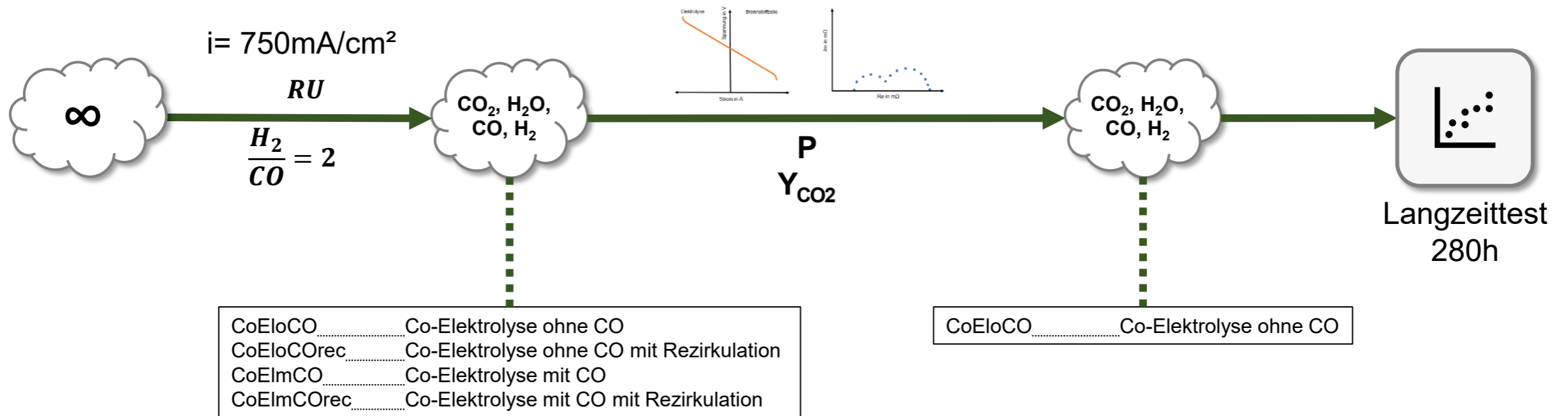

Auswahl eines Gasgemisches für die Co-Elektrolyse

$T = 800^{\circ}\text{C}$
 Fuel = 1.1slpm
 Air = 0.55slpm
 $i = 750\text{mA/cm}^2$

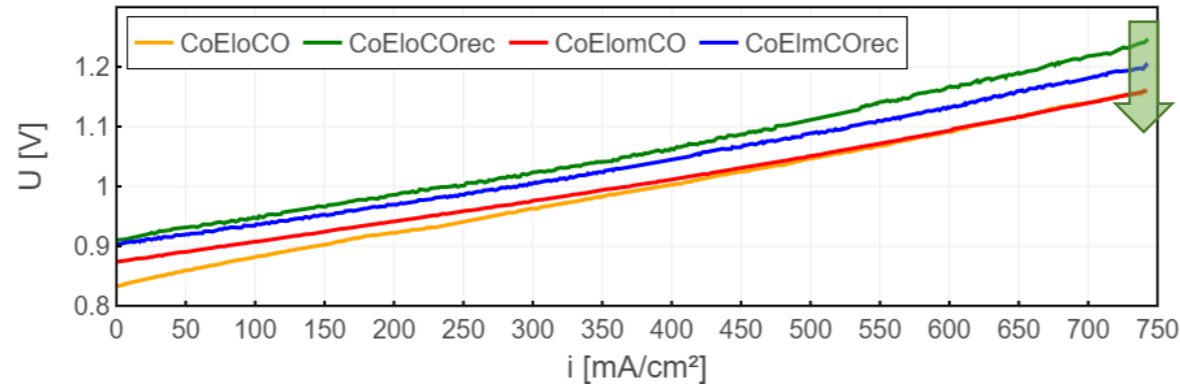

→ $U \downarrow$ relevant

→ 2 Gaszusammensetzungen möglich

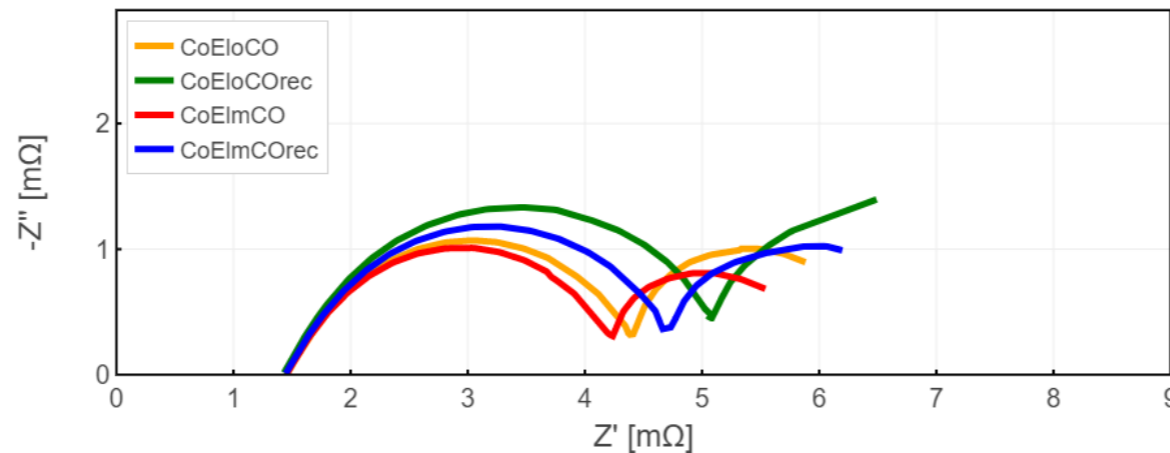

→ weitere Entscheidungskriterien nötig

Auswahl eines Gasgemisches für die Co-Elektrolyse

$$\Delta P = \frac{|P_{\text{experiment}} - P_{\text{CoEloCO}}|}{P_{\text{CoEloCO}}} \cdot 100\%$$

$$X_{\text{CO}_2} = \frac{\dot{V}_{\text{tot,dry,in}} \cdot Y_{\text{CO}_2,\text{dry,in}} - \dot{V}_{\text{tot,dry,out}} \cdot Y_{\text{CO}_2,\text{dry,out}}}{\dot{V}_{\text{CO}_2,\text{dry,in}}}$$

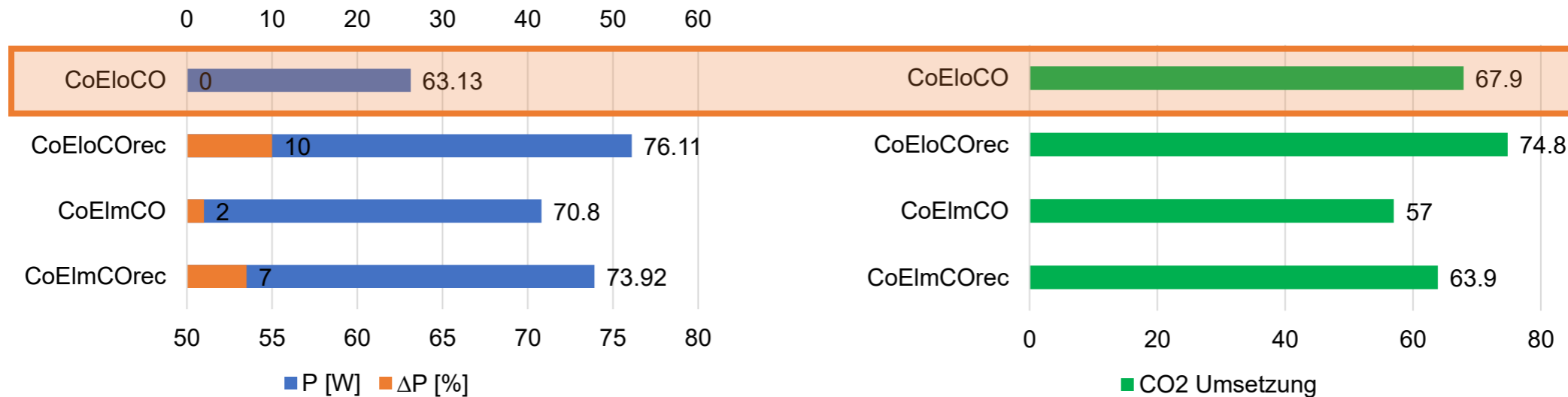

Langzeitversuch

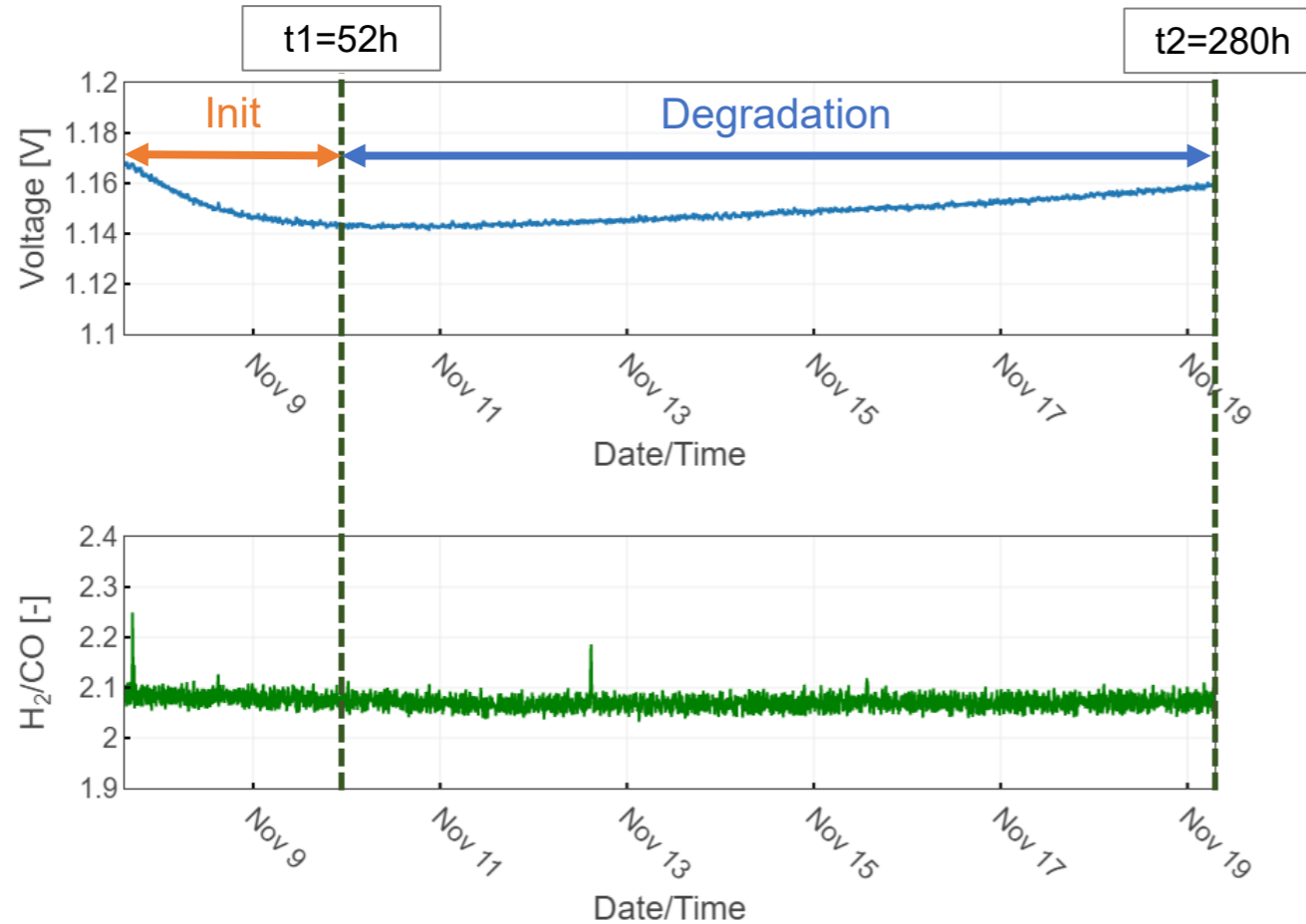

$$r_d = \frac{U_{t2} - U_{t1}}{U_{t1}} \cdot \frac{1}{t2 - t1} \cdot 1000 \frac{h}{h} \cdot 100\%$$

→ 6.01%/1000h

→ H₂/CO ≈ 2.08

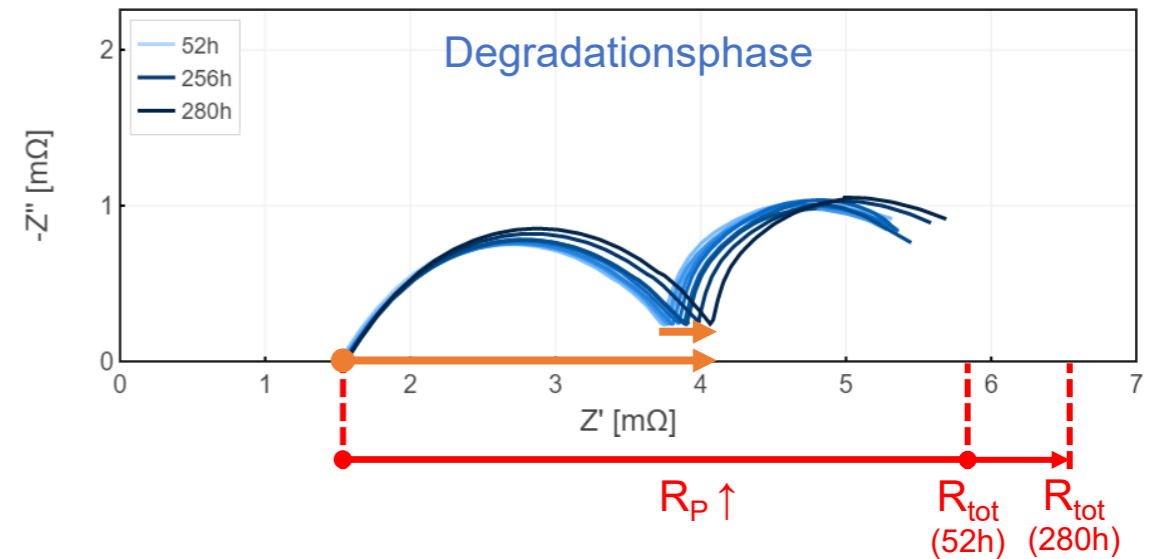

Langzeitversuch

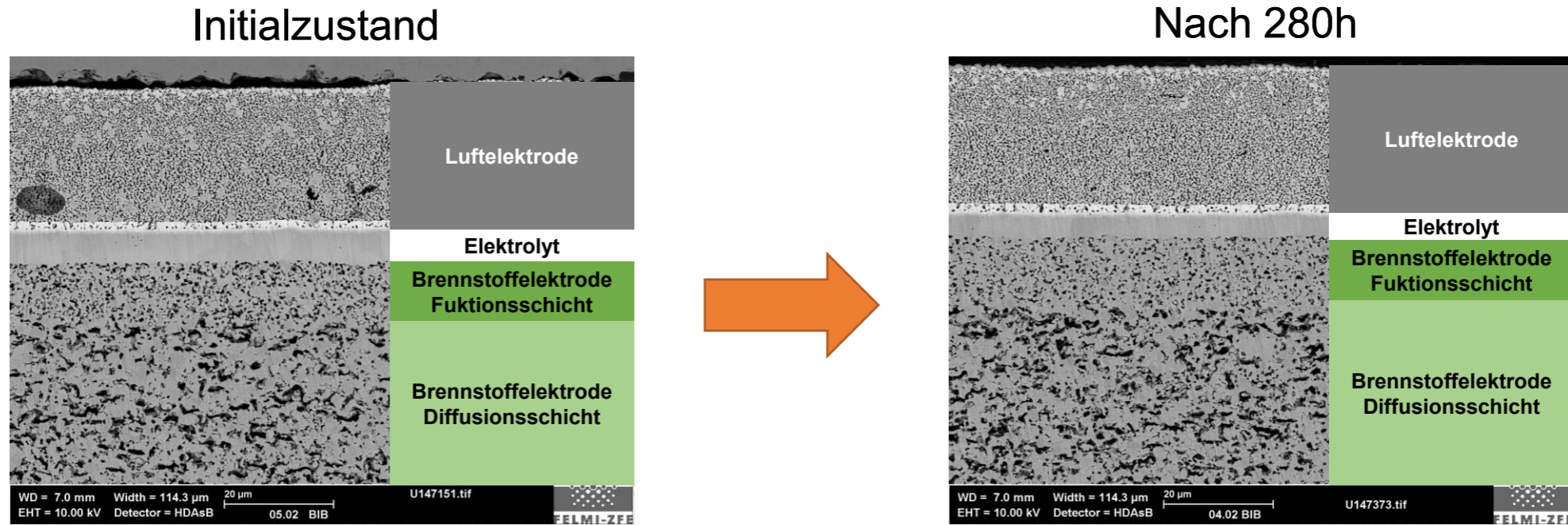

→ Porosität der Funktionsschicht: 19% → 17%

→ Porosität der Diffusionsschicht: 23% → 26%

Highlights

- Degradationsrate von 6.01%/1000h
- Stabiles H₂/CO über die Degradationsphase
- Porosität der Funktionsschicht ↓
- Porositäts der Diffusionsschicht ↑

Zusammenfassung & Ausblick



**Analyse des Einflusses
von Betriebsparametern**
→ Langzeiteffekte

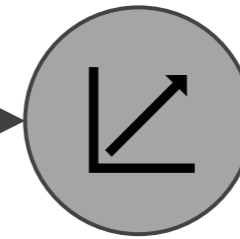
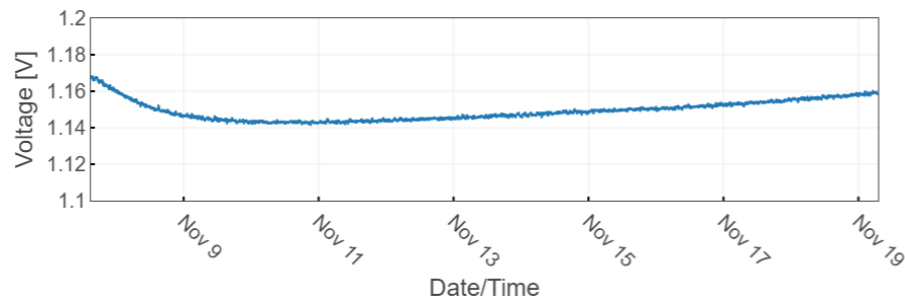

**Optimierung der
Betriebsumgebung**

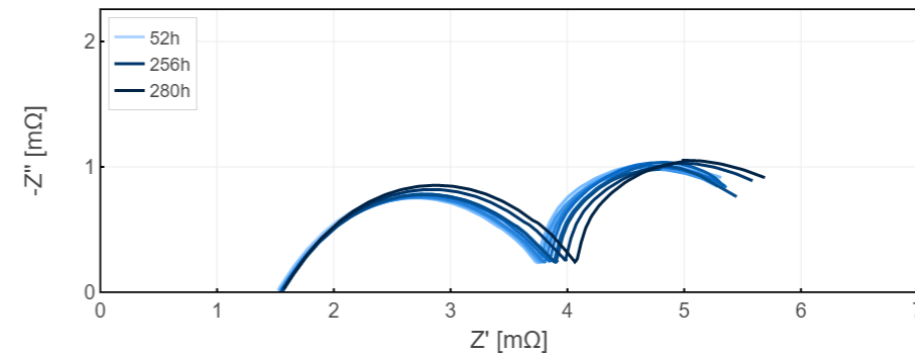

Zusammenfassung & Ausblick

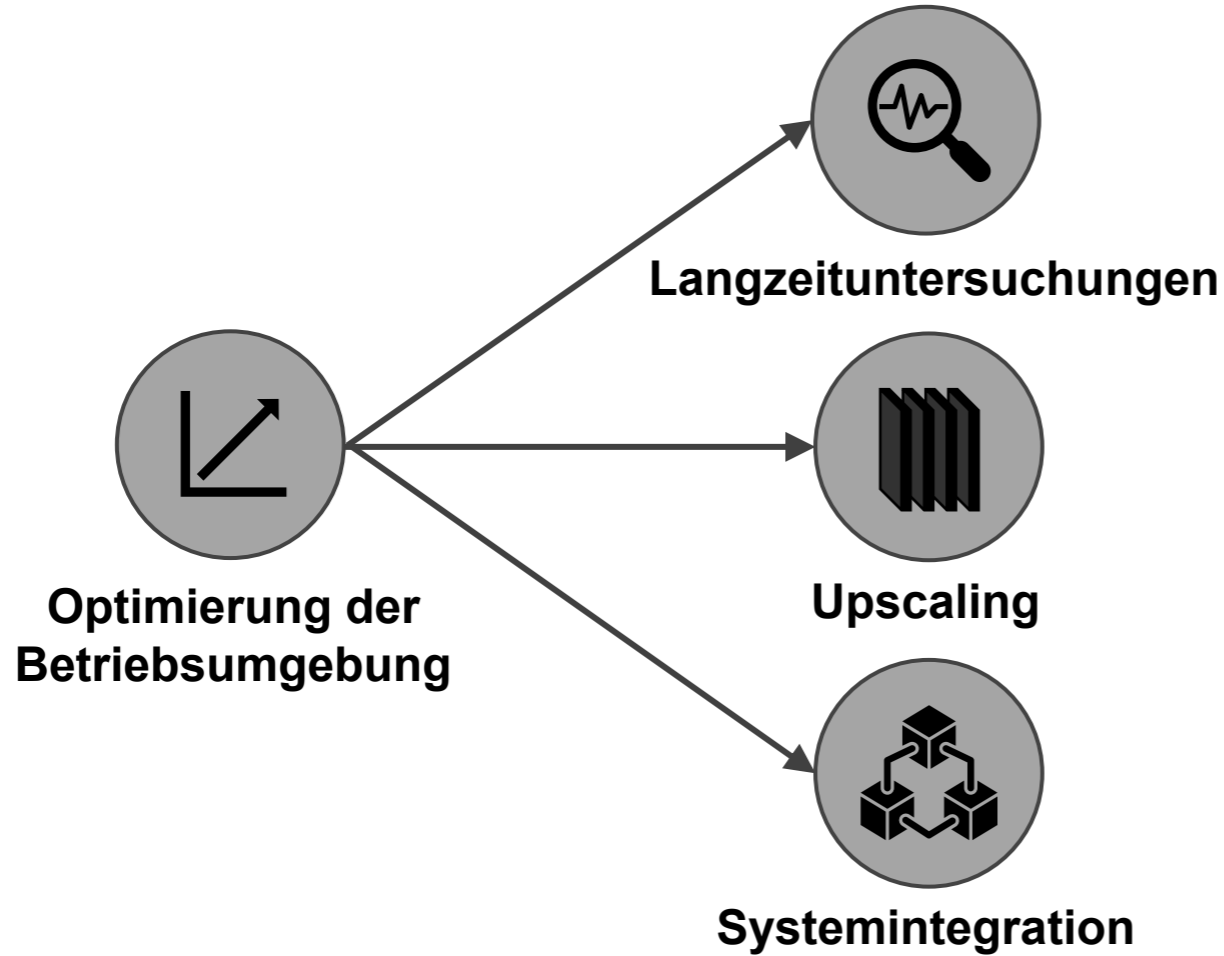

→ MeOH-Synthese

→ FT-Synthese

→ Methanisierung

→ Stack-level Untersuchung

Danke für Ihre Aufmerksamkeit.



Dipl.-Ing. Daniel Reiner

daniel.reiner@tugraz.at

+43 316 873 7805

Technische Universität Graz
Institut für Wärmetechnik (IWT)
Inffeldgasse 25/B
8010 Graz



SCAN ME