

ASSESSMENT OF SYSTEM STRENGTH METRICS FOR SMALL-SIGNAL STABILITY ANALYSIS IN POWER ELECTRONICS DOMINATED GRIDS

Alonso Conejos Lopez

12.02.2026

- **Need for new definition of system strength**
 - Traditionally equated to Short Circuit Ratio (SCR), seen as overarching concept
 - As inverters populate the grid, traditional metrics no longer work
 - Grid characteristics change fast, dependent on energy mix, topology, operating point...

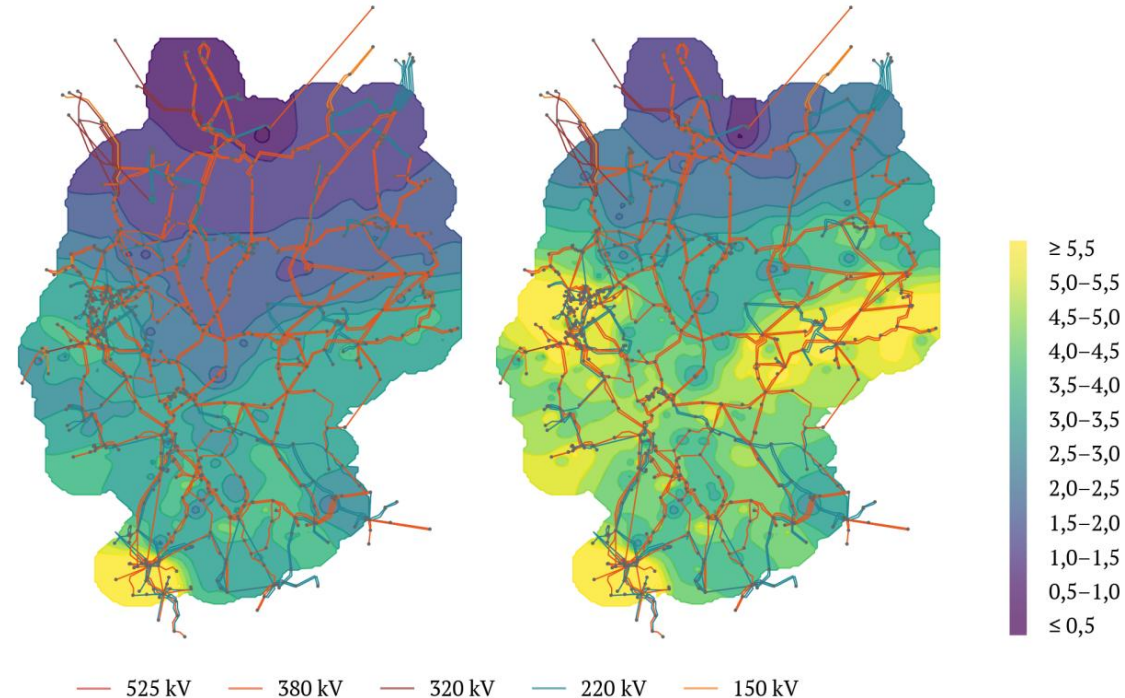

ESCR for scenarios with Moderate conventional Generation (left) and high conventional generation (right)

"Systemstabilitätsbericht." 50Hertz Transmission GmbH, Amprion GmbH, TenneT TSO GmbH, and TransnetBW GmbH. 2025.

- Different Definitions from IEEE, CIGRE, NERC, AEMO, National Grid...
- **Compounded definition**
 - Sensitivity of **voltage magnitude**, **phase angle**, and **voltage waveform** at any given transmission grid location with respect to the **change in active/reactive power** in every possible system condition (with/without disturbances).

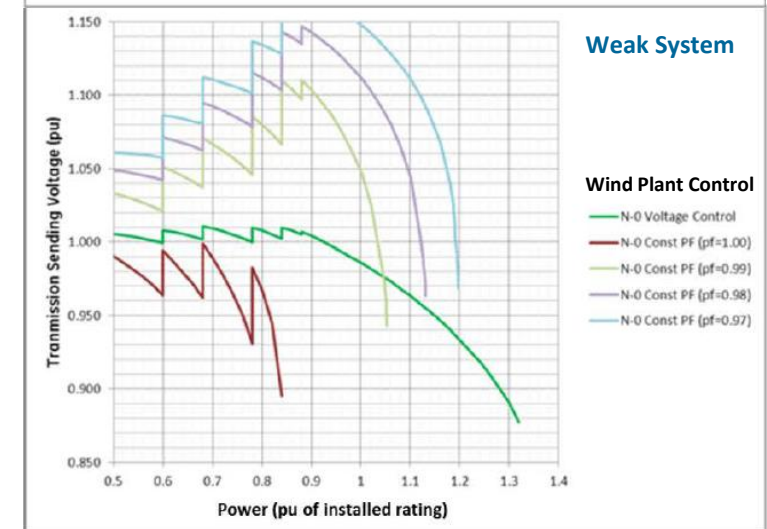
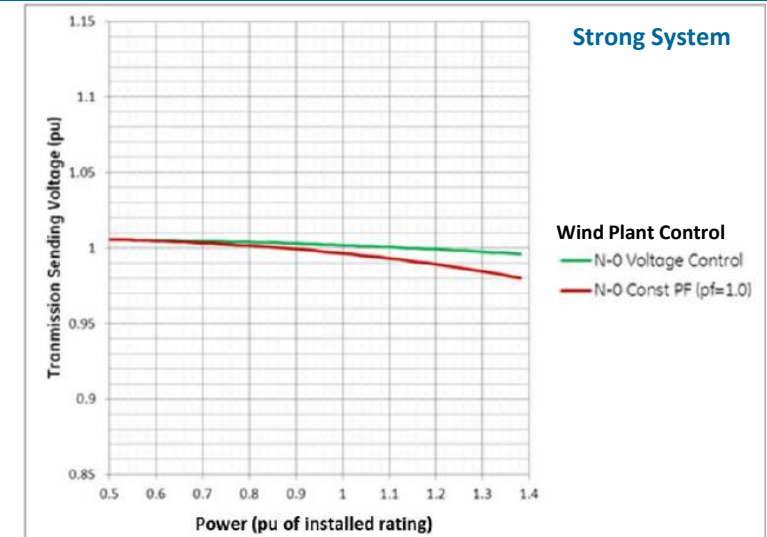

Grid Strength, Voltage Stability, and Wind Plant Control. Source: GE

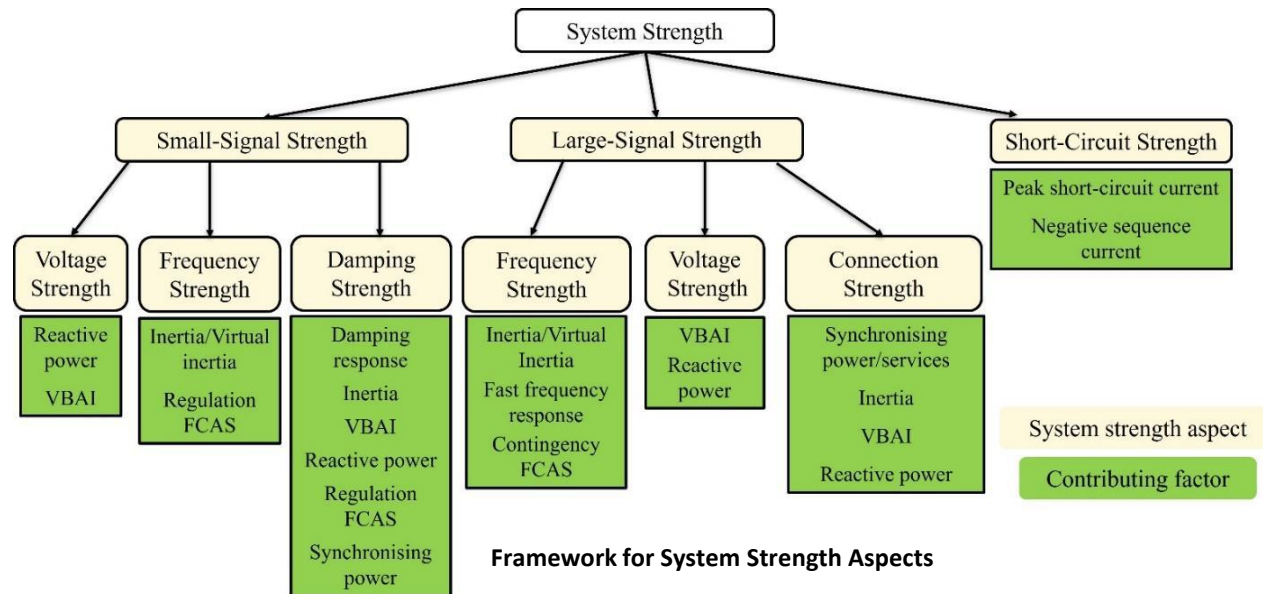

"System Strength Beyond Fault Level". Mehdi Ghazavi Dozein, 2025

- Traditionally used for system planning purposes – long term horizon
- Connection with small-signal stability analysis and system operation
- Weak systems are more likely to experience:
 - Oscillations
 - Interactions between inverters
 - Stronger reactions to disturbances

- Challenges and issues in weak grids:
 - Oscillation modes can limit transfer capacity
 - Instabilities driven by the slow converter control loops, such as PLL or voltage controller
 - Desynchronization in case of a disturbance (harder to track waveforms)
 - Harmonics and flickers

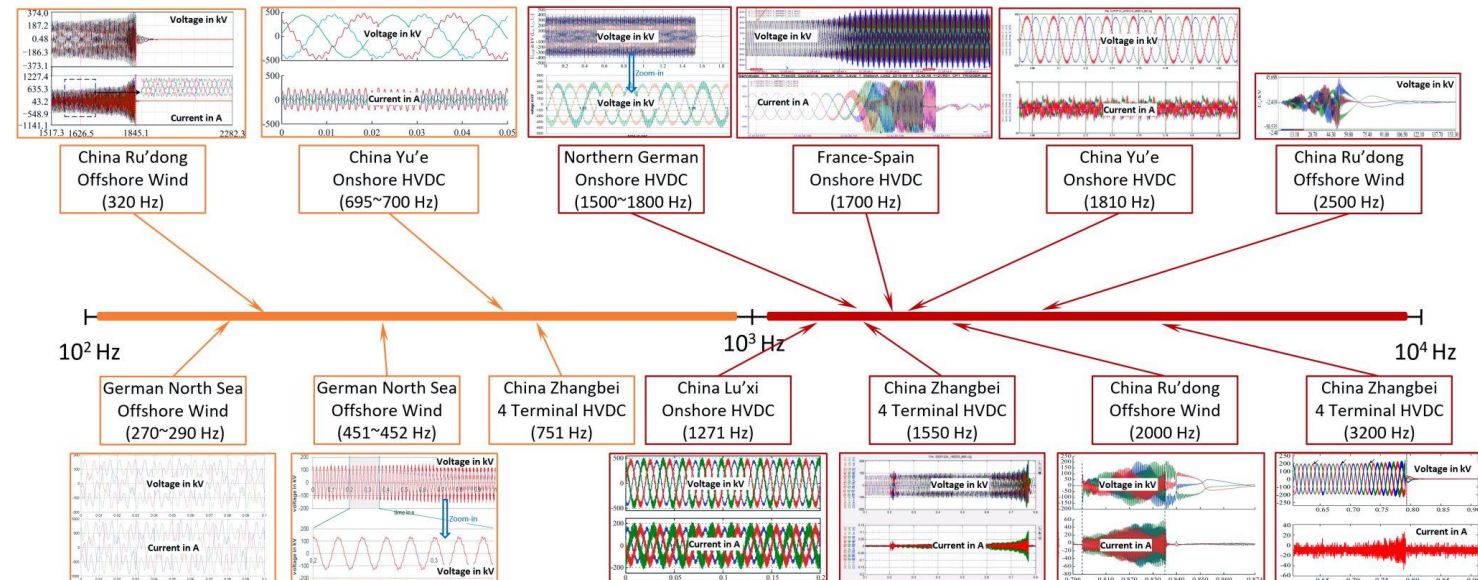

Real-Life HVDC Events

"System Strength Beyond Fault Level". Mehdi Ghazavi Dozein, 2025

"Utilizing Equivalent Short-Circuit Ratio (ESCR) approach for assessing the slow converter driven stability and tuning the voltage controllers." Fingrid, 2023

"Integrating Inverter-Based Resources into Low Short Circuit Strength Systems." NERC 2017

"Wideband Impedance Passivation of MMCs for Suppressing Harmonic Oscillations". Pengxiang Huang, 2024

Traditional System Strength Metrics Assessed in This Study

Short Circuit Ratio (SCR)

- Simplest metric
- Ratio of short circuit current to the installed capacity at the bus being tested.

$$SCR = \frac{SC_{MVA,i}}{P_i}$$

For:

- $SC_{MVA,i}$ = Short Circuit Current at bus i
- P_i = Power rating of IBR under test
- $\frac{\Delta V_j}{\Delta V_i}$ = interaction factor

Equivalent Short Circuit Ratio (ESCR)

- Accounts for nearby devices
- Applies an interaction factor to give different weights to other buses

$$ESCR = \frac{SC_{MVA,i}}{P_i + \sum \frac{\Delta V_j}{\Delta V_i} \cdot P_j}$$



These metrics do not consider inverter behavior, but for modern grids it is important to consider it e.g. through admittance models

Impedance-Based System Strength Metrics Assessed in This Study

Impedance Margin Ratio (IMR)

- Relates changes to the system impedance to changes to the system eigenvalues and calculates a stability margin
- Focused on small-signal stability

$$\text{IMR} = \frac{\|\Delta Z_{AK}(\lambda)\|_{max}}{\|Z_{AK}(\lambda)\|}$$

$$\text{for } \|\Delta Z_{AK}(\lambda)\|_{max} = \frac{|\sigma|}{\|Res_{\lambda}^* Y_{kk}^{sys}\|}$$

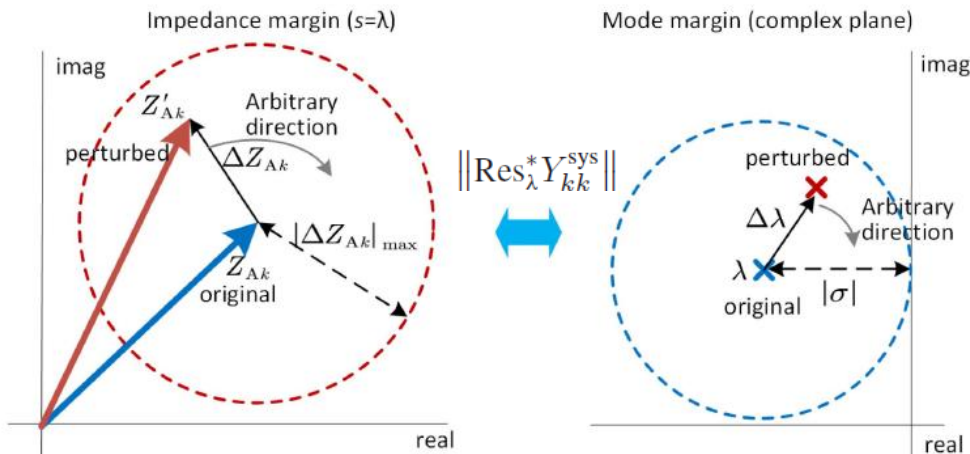

Conceptual Visualization of IMR in the complex plane

For:

- $Z_{AK}(\lambda)$ = original impedance of apparatus connected to bus k
- $\| \cdot \|$ = Frobenius norm
- σ = real part of system eigenvalues
- $Res_{\lambda}^* Y_{kk}^{sys}$ = conjugate transpose of the residue matrix of the system admittance matrix

"Impedance Margin Ratio: A New Metric for Small-Signal System Strength." Yue Zhu, 2024

• IEEE Standard 57 Bus System

- Measure **SCR**, **ESCR**, and **IMR** at all active buses
- EMT simulation is run to check for signs of small-signal instability and assess system strength metrics
 - Small-signal disturbance is introduced at bus 9 after 1s of simulation. System dynamic response is observed.

• Tested across 3 different scenarios

- **Base Scenario:** System is kept as-is for a **baseline**
- **GFL Scenario:** Synchronous Generators (SGs) **3**, **9**, and **12** are swapped for a **Grid Following (GFL) inverter** of the same power rating and similar parameters.
- **Detuned Scenario:** **PLL** bandwidth for GFL Inverters **3**, **9**, and **12** is purposely detuned.

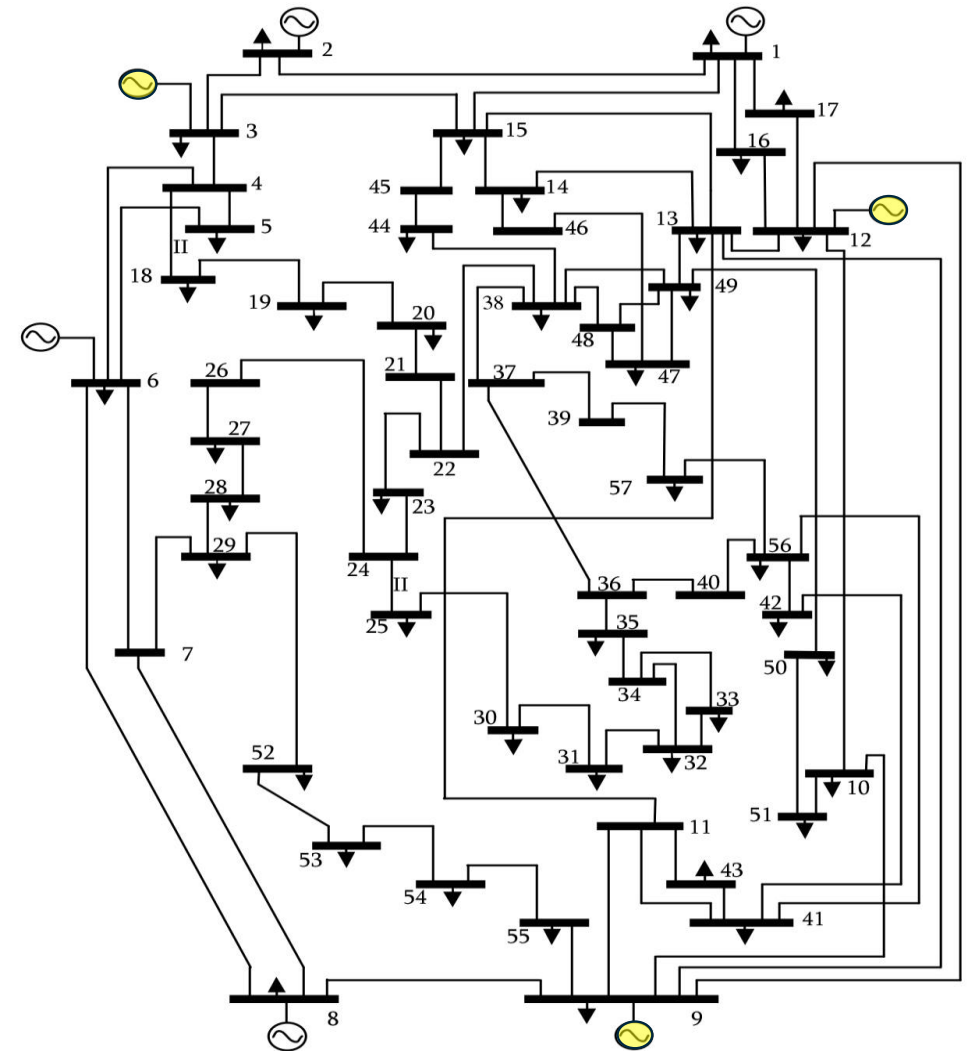

Results – Metrics

Base Scenario

Bus	SCR	ESCR	IMR
1	8,49	2,38	0,50
2	45,23	2,17	0,16
3	20,84	1,42	0,13
6	19,30	0,91	0,30
8	5,69	1,50	0,066
9	35,59	1,72	0,24
12	5,71	1,13	0,051



GFL Scenario

Bus	SCR	ESCR	IMR
1	7,48	2,10	0,35
2	40,87	1,97	0,19
3*	20,13	1,37	0,35
6	17,06	0,80	0,21
8	3,18	0,84	0,072
9*	29,52	1,43	0,38
12*	4,68	0,93	0,0013



Detuned Scenario

Bus	SCR	ESCR	IMR
1	7,48	2,10	0,35
2	40,87	1,97	0,19
3*	20,13	1,37	0,01
6	17,06	0,80	0,21
8	3,18	0,84	0,072
9*	29,52	1,43	0,0022
12*	4,68	0,93	0,0042

Legend:

- TEXT** Weakest bus in this scenario, according to each metric
- Notably increased (> +30%)
- Notably decreased (< -30%)
- Significantly decreased (< -80%)
- * Buses changed from previous scenario

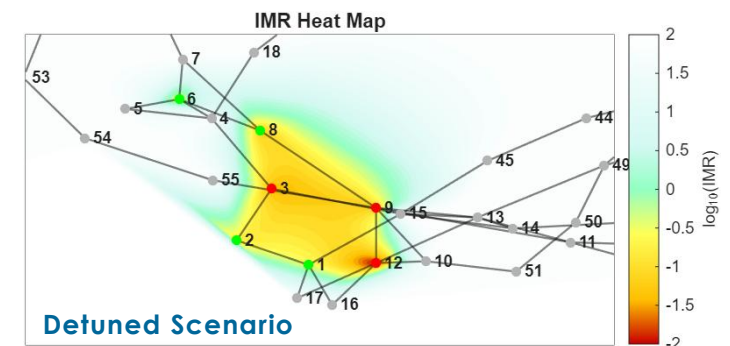
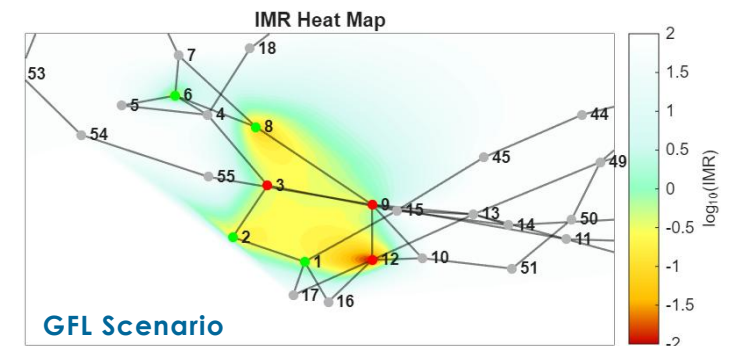
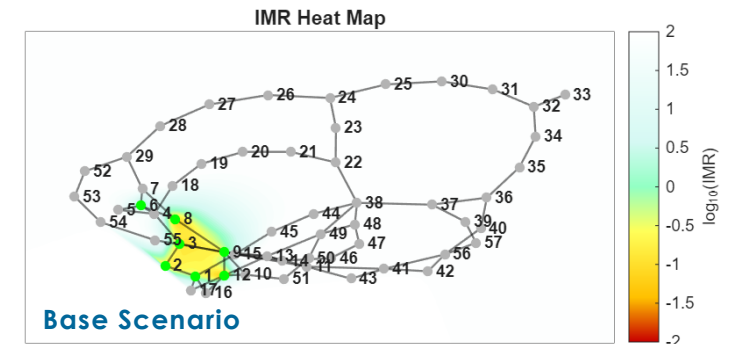

Results – Simulation



Base Scenario

GFL Scenario

Detuned Scenario

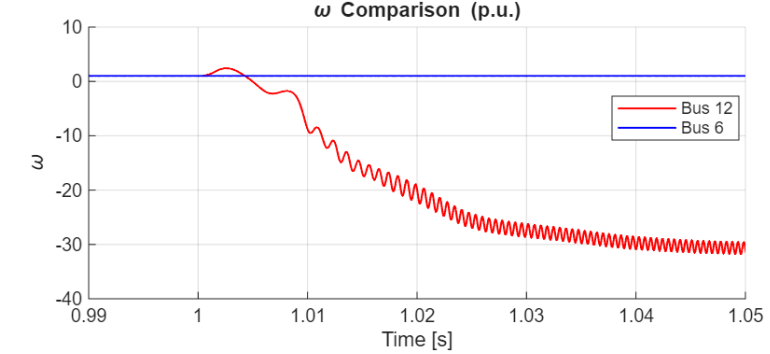
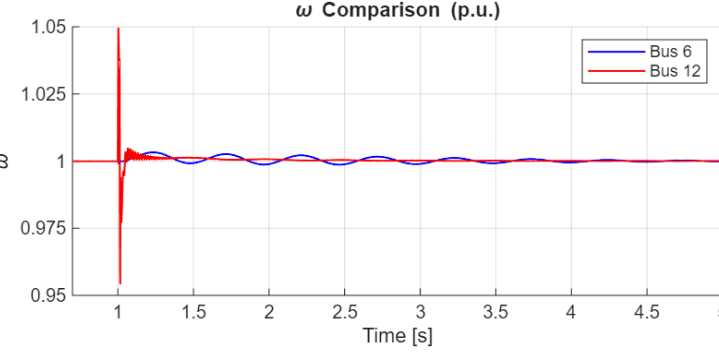
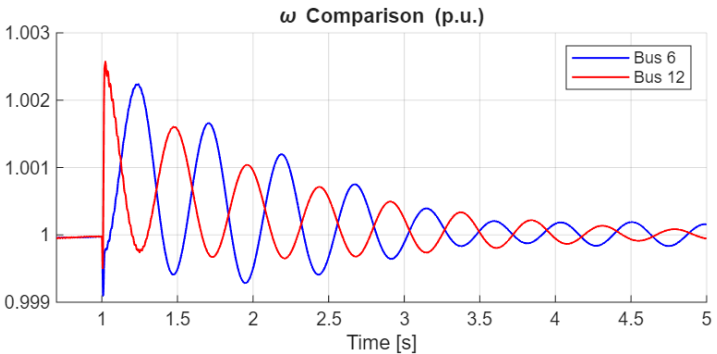
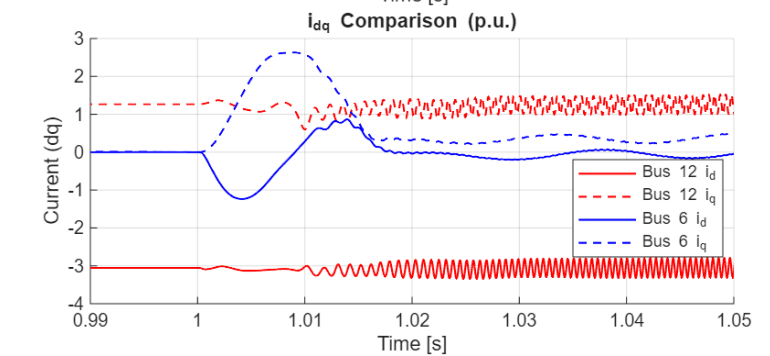
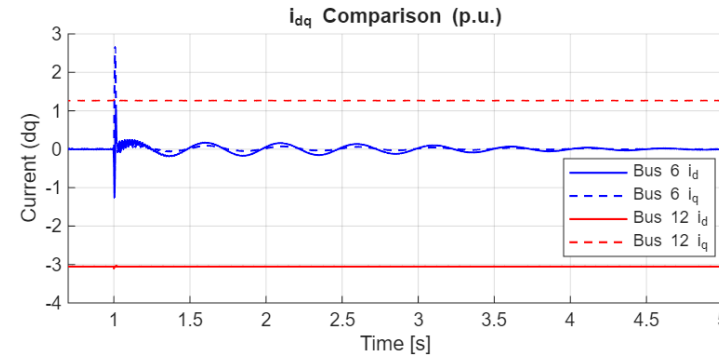
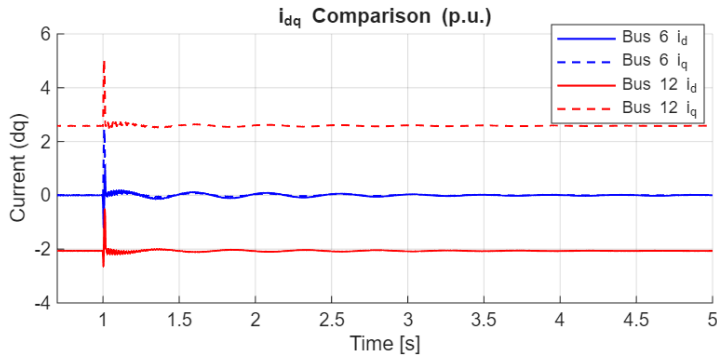
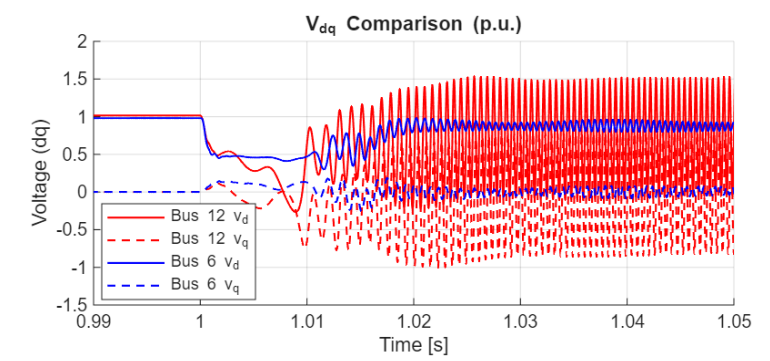
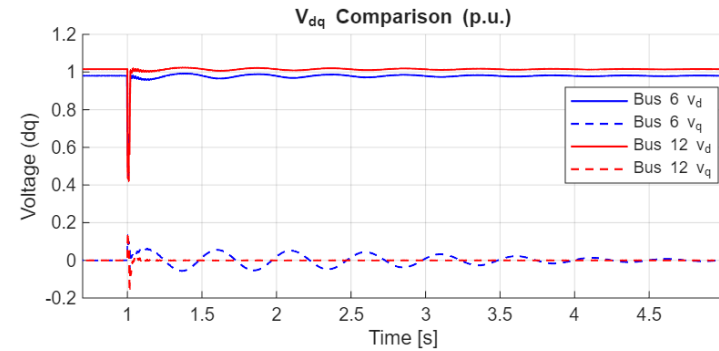
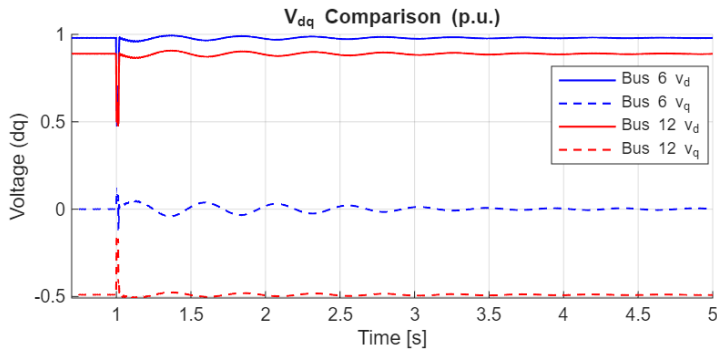

- **All metrics changed when GFLs were introduced, but only IMR changed when parameters were detuned**
- **SCR and ESCR account for short circuit level at operating frequency, but neglect the rest of the frequency spectrum**
 - No difference in these metrics between GFL and Detuned scenarios, where high frequency oscillations appear.
- **Individual bus weakness does not mean instabilities *will* happen.**
 - Bus 9, with lowest IMR values, exhibited less pronounced oscillations than other buses with higher IMR values.
- **The metrics did not always accurately predict when a bus would be unstable.**
 - Bus 12 in GFL vs. Detuned scenarios.
 - IMR does serve as an indication of when and where small signal stability may arise.

Thank You!

 PSS2030+

Any Questions?

Alonso Conejos Lopez

Power and Renewable Gas Systems

Center for Energy

AIT-Austrian Institute of Technology GmbH

alonso.conejos@ait.ac.at

 <https://www.linkedin.com/in/alonso-conejos-lopez-079304207/>

Appendix: Apparatus Parameters



GFL Scenario

Bus number	Apparatus type	Vdc (pu) = 2.5	Cdc (pu)	wL (pu)	R (pu)	Bandwidth vdc (Hz)	Bandwidth PLL (Hz)	Bandwidth idq (Hz)	
1		0	14.000	40.000	0.075	0.013			
2		0	3.500	10.000	0.300	0.050			
3		11	2.500	1.250	0.300	0.050	20.000	20.000	1000.000
4		100							
5		100							
6		0	3.500	10.000	0.300	0.050			
7		100							
8		0	3.500	10.000	0.300	0.050			
9		11	2.500	1.250	0.300	0.050	20.000	20.000	1000.000
10		100							
11		100							
12		11	2.500	1.250	0.300	0.050	20.000	20.000	1000.000

Detuned Scenario

Bus number	Apparatus type	Vdc (pu) = 2.5	Cdc (pu)	wL (pu)	R (pu)	Bandwidth vdc (Hz)	Bandwidth PLL (Hz)	Bandwidth idq (Hz)	
1		0	14.000	40.000	0.075	0.013			
2		0	3.500	10.000	0.300	0.050			
3		11	2.500	1.250	0.300	0.050	20.000	600.000	1000.000
4		100							
5		100							
6		0	3.500	10.000	0.300	0.050			
7		100							
8		0	3.500	10.000	0.300	0.050			
9		11	2.500	1.250	0.300	0.050	20.000	500.000	1000.000
10		100							
11		100							
12		11	2.500	1.250	0.300	0.050	20.000	500.000	1000.000

